

SS-12D28-GXXX

直柄

G-Switch P/N

Switch Height (mm)

- G020=2.0 G030=3.0
- G040=4.0 G050=5.0
- G055=5.5 G060=6.0
- G065=6.5 G070=7.0
- G075=7.5 G080=8.0
- G085=8.5 G090=9.0
- G095=9.5 G100=10.0

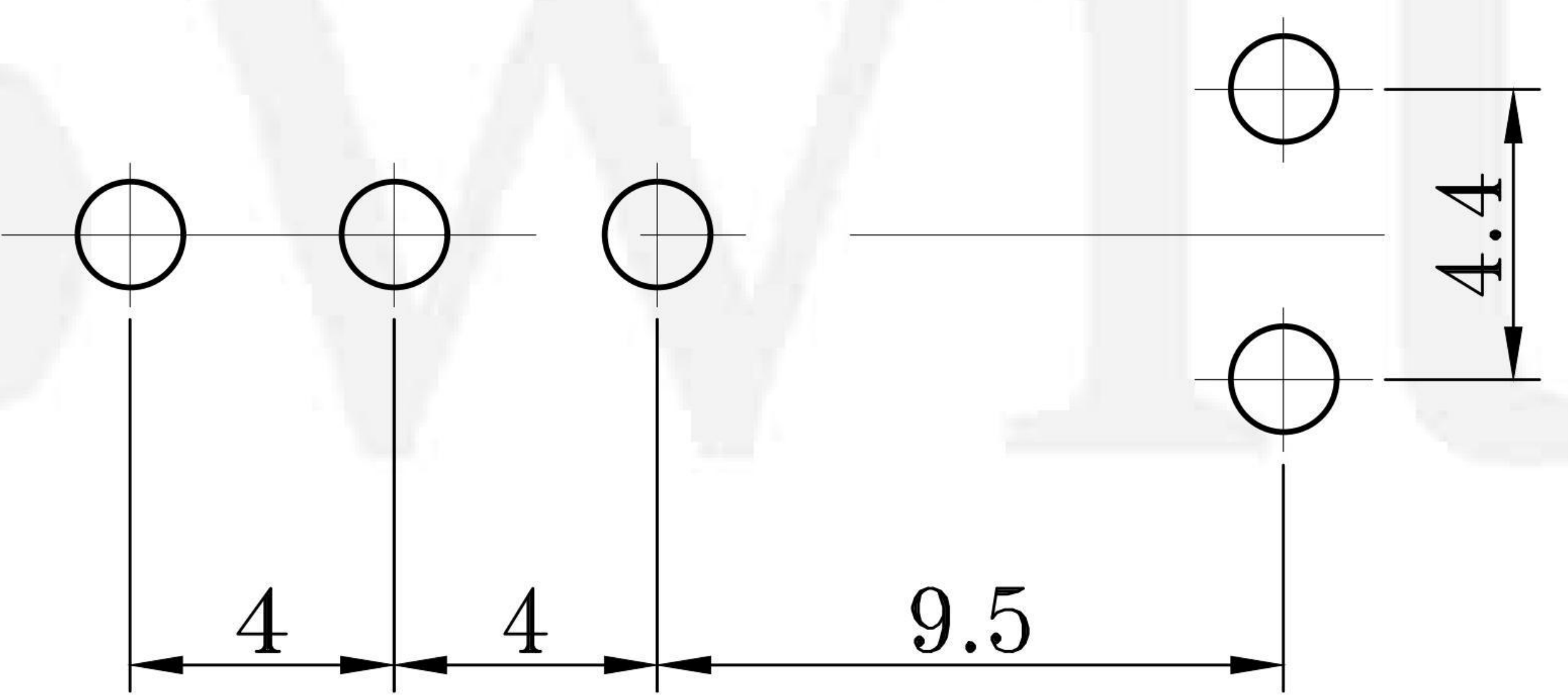
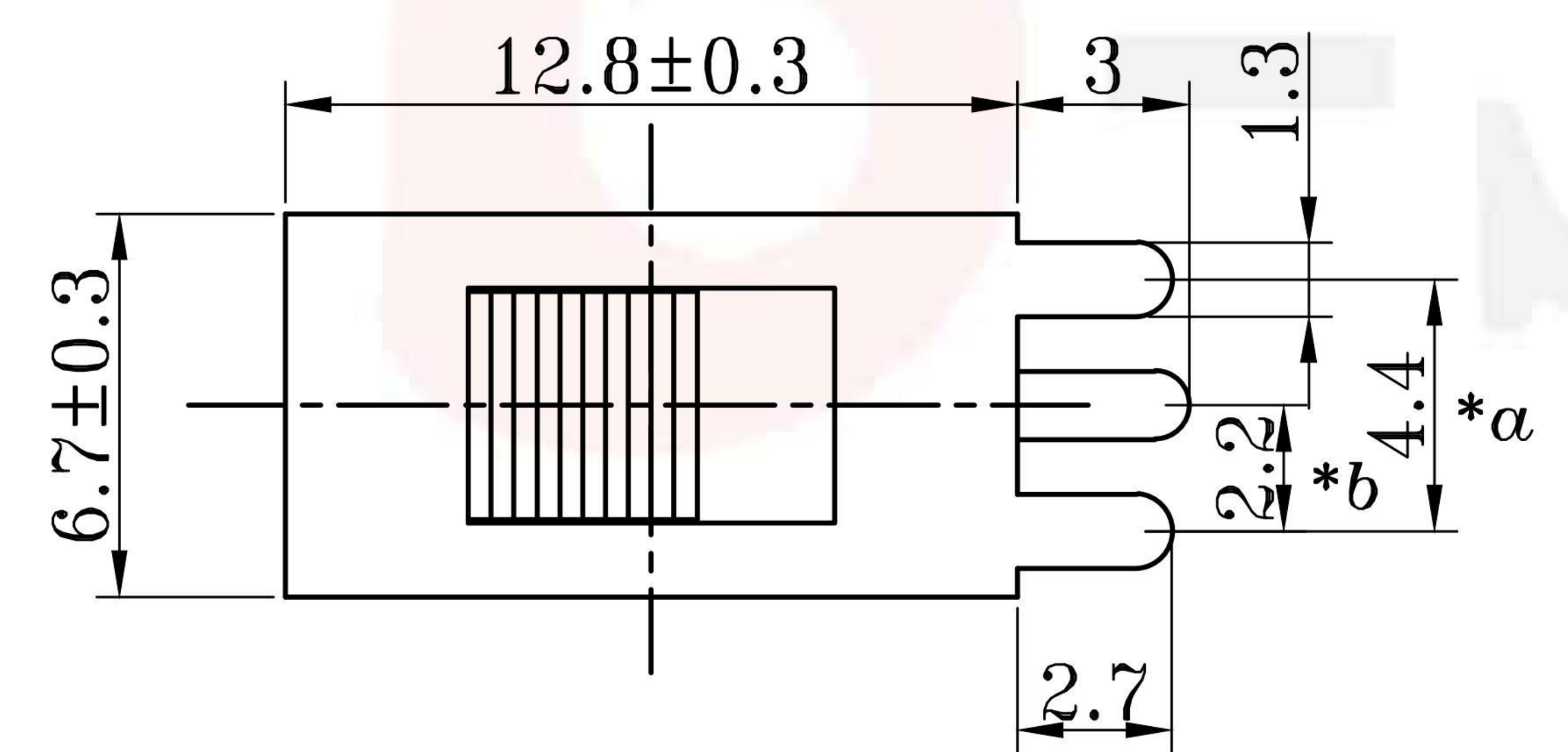

PCB LAYOUT

G-Switch Specification:

Electrical Specifications: 3.0A/DC24V
 Contact resistance (CR): ≤50mΩ
 Insulation Resistance(IR): ≥100MΩ DC250V
 Compressive strength (WV): AC250V 1minute
 Operating temperature: -25°C~+70°C
 Storage humidity: <85%RH
 Electrical life: 10,000Cycles.

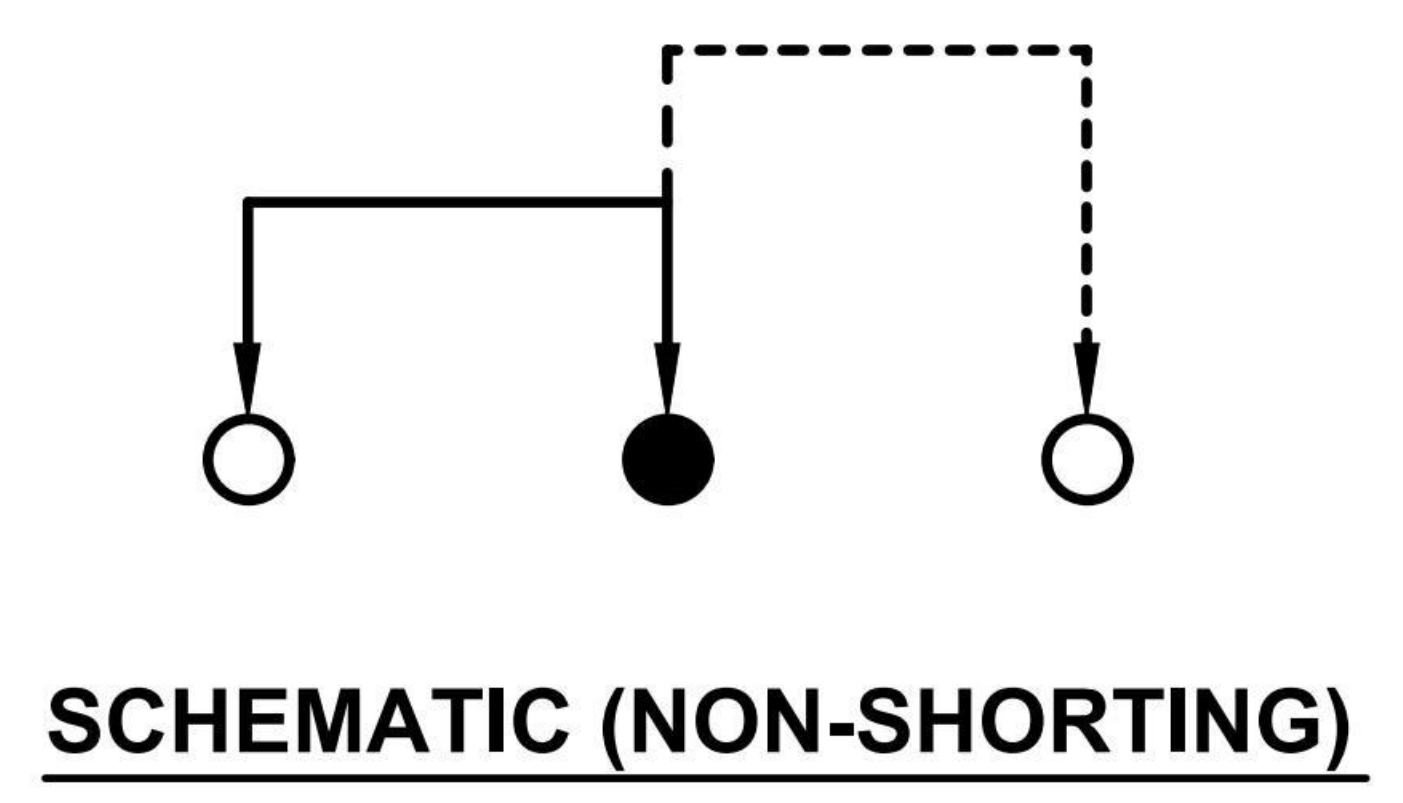

G-Switch Electronic (HongKong) CO.,Ltd.

Unless otherwise specified, Tolerance: X. ±0.30 X.x ±0.20 X.xx ±0.15 X.xxx ±0.10 Angles ±3°	DESIGN Yvette Chen	DATE 2019.05.29	Molde code:		
	CHECKED	DATE	SS-12D28-GXXX		
	APPROVED	DATE	REV.: X1	SCALE: 4:1	UNIT: mm
	http://www.dg-switch.com		SIZE: A4	SHEET: 1/1	
TEL:0769-82388879					