

MS-22D17-GXXX

直拨形式

G-Switch P/N

Switch Height (mm)
 G020=2.0 G025=2.5
 G030=3.0 G040=4.0

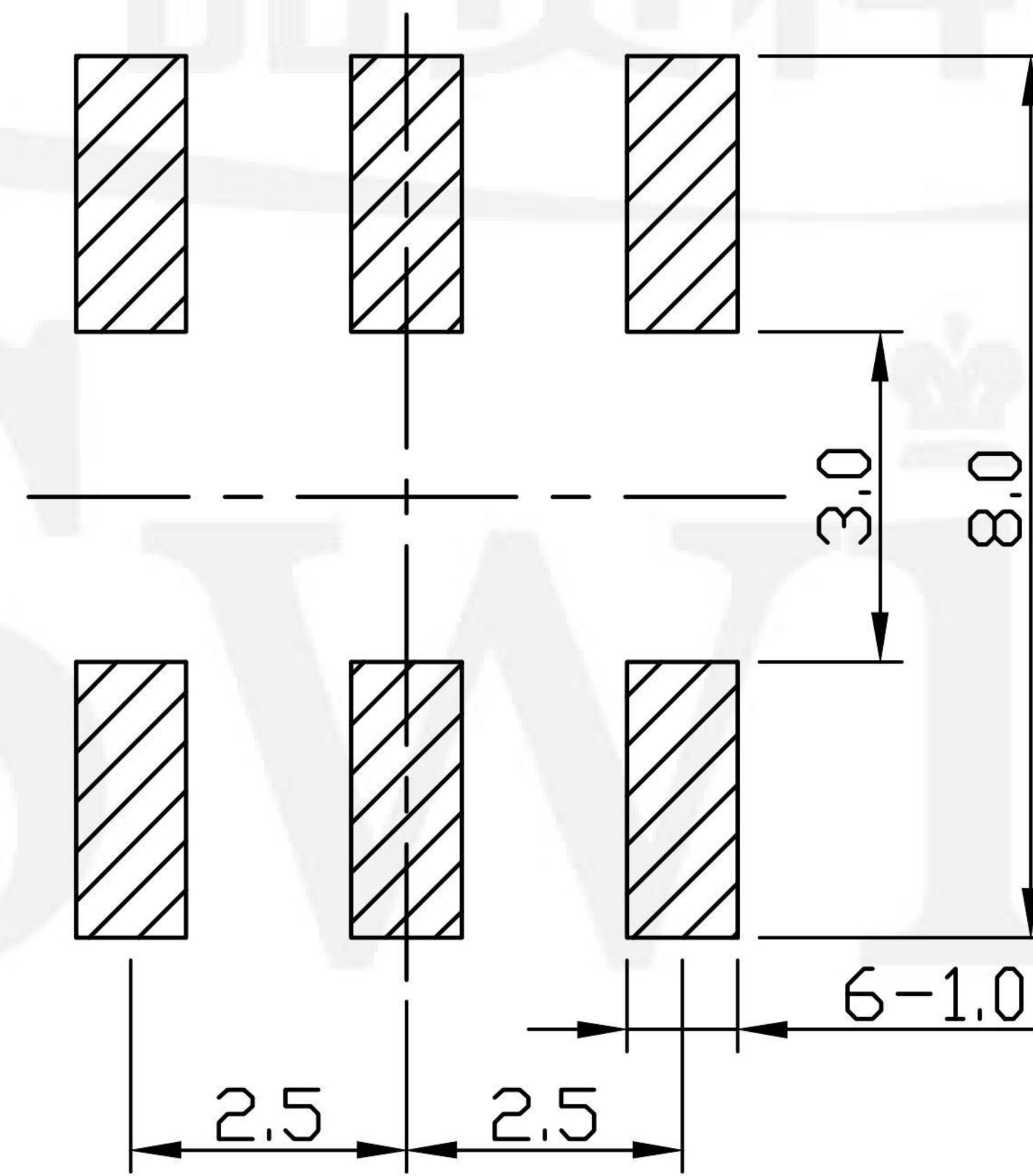
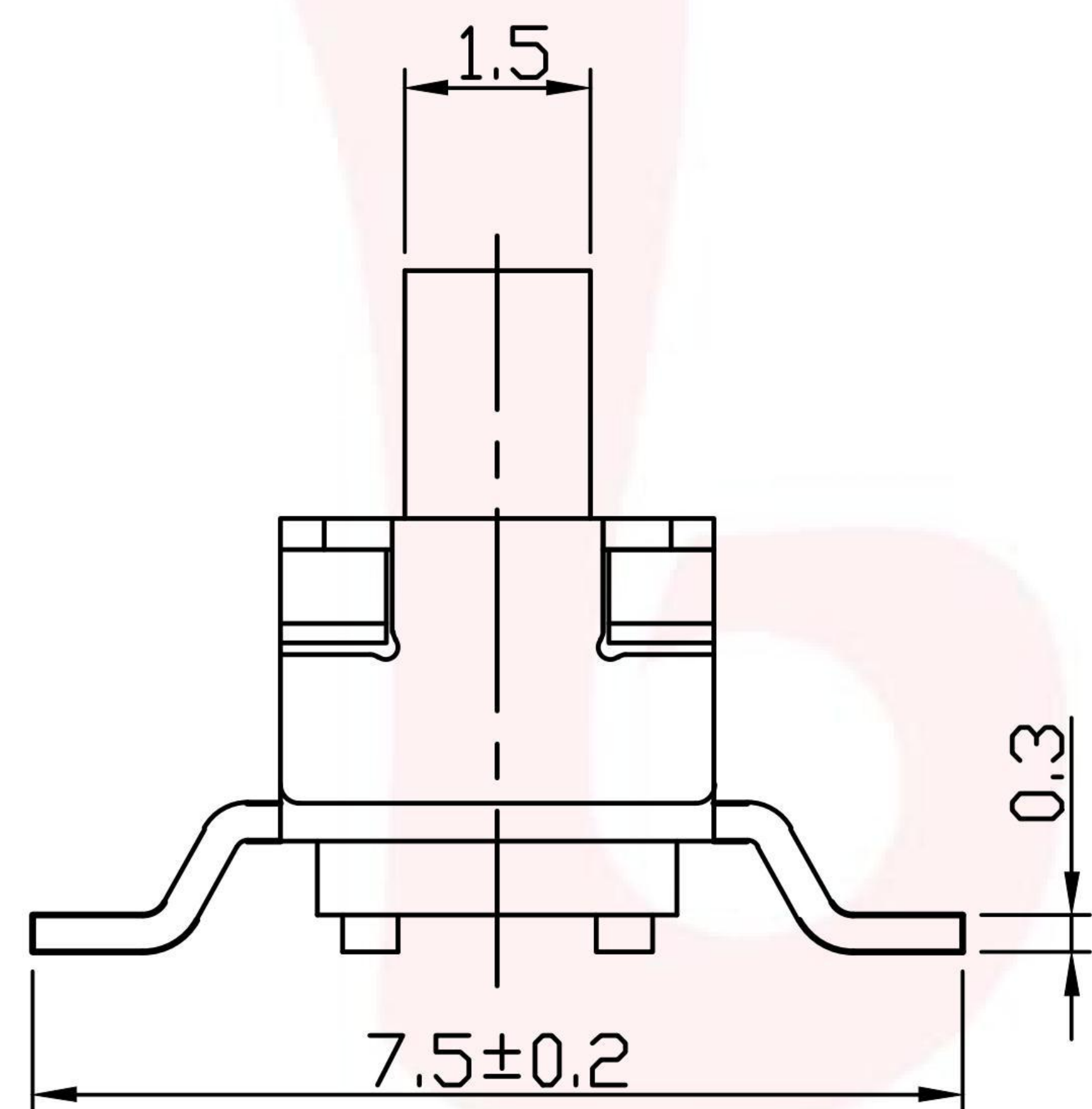

P.C.B LAND DIMENSION

G-Switch Specification:

Electrical Specifications: DC 12V 0.5A DC 6V 1.0A
 Contact Resistance : 100mΩMAX
 Insulation Resistance: 100M ohm 100V DC
 Withstand Voltage: AC 250V for 1 min
 Ambient Temperature: -20°C~+70°C
 Relative Humidity: (40°C)≤85%
 Reflow soldering: 250°C MAX
 Life: 10,000 times

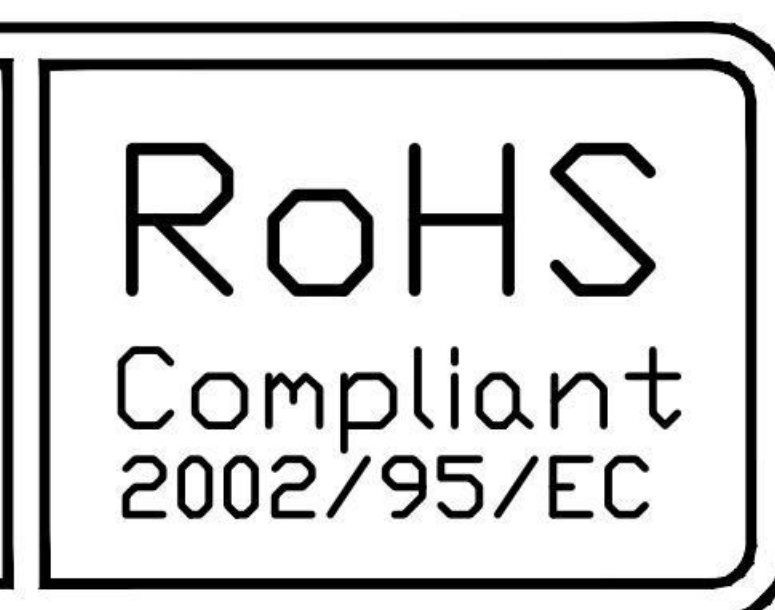
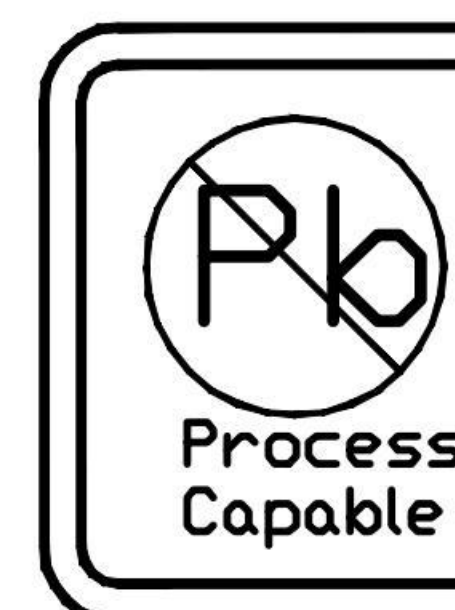
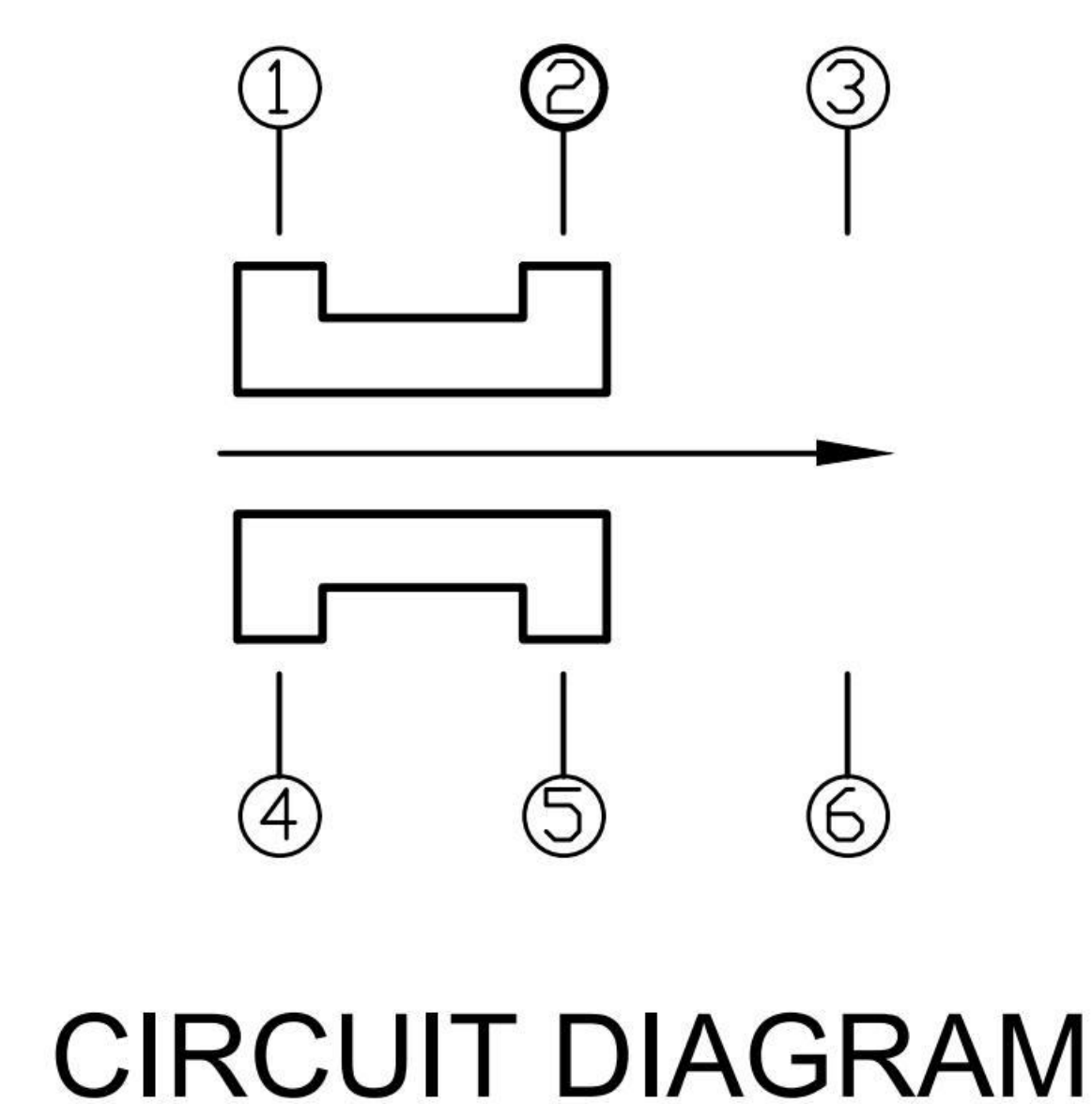

G-Switch Electronic (HongKong) CO.,Ltd.

Unless otherwise specified, Tolerance:
 X. ±0.30
 X.x ±0.20
 X.xx ±0.15
 X.xxx ±0.10
 Angles ±3°

DESIGN FengFengChen DATE 2019.05.29
 CHECKED DATE
 APPROVED DATE
<http://www.dg-switch.com>
 TEL:0769-82388879

Molde code:
MS-22D17-GXXX
 REV.: X1 SCALE: 4:1 UNIT: mm
 SIZE: A4 SHEET: 1/1