

MK-42C10-GXXX

侧拨形式
G-Switch P/N

Switch Height (mm)
G020=2.0
G030=3.0
G040=4.0

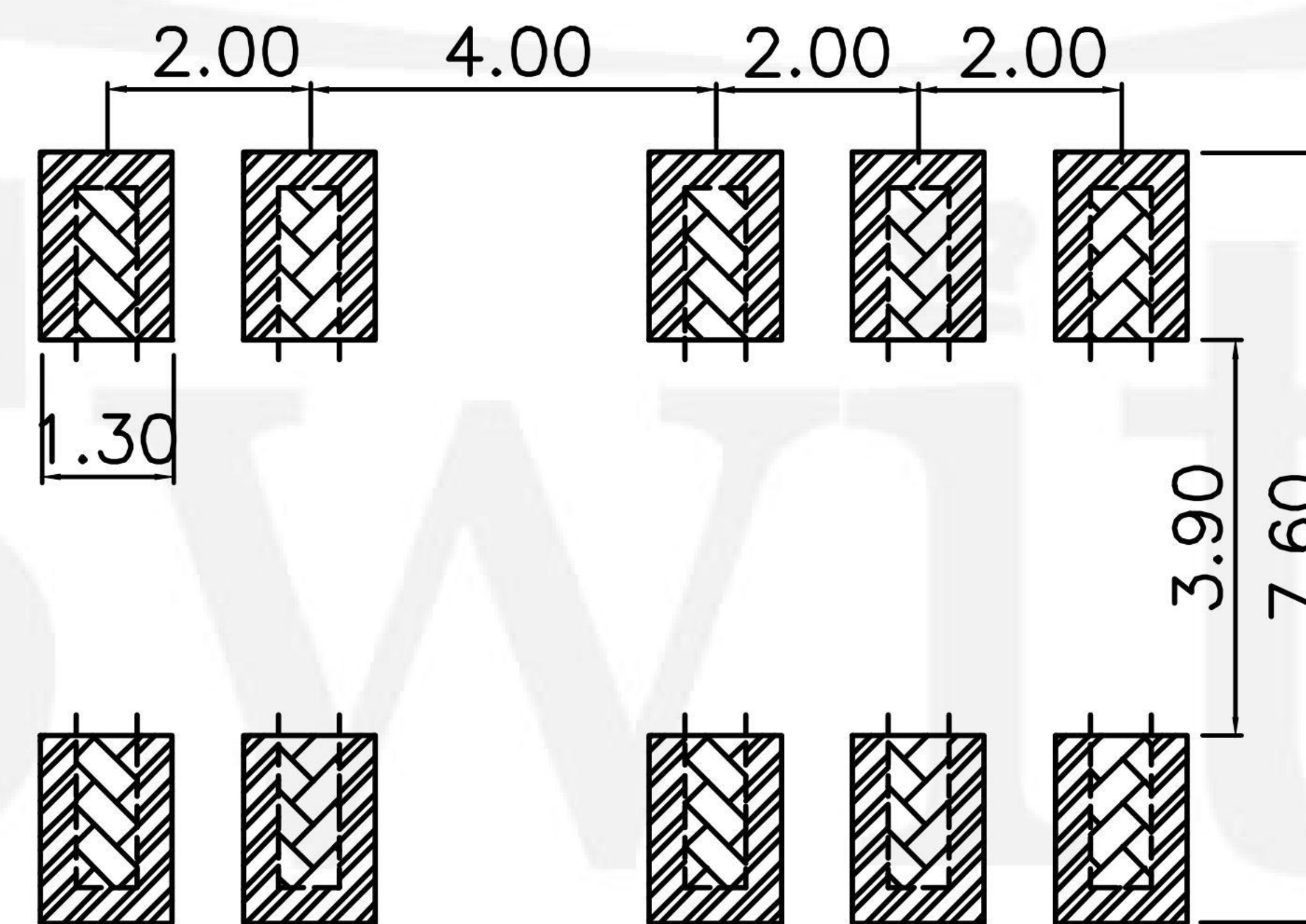
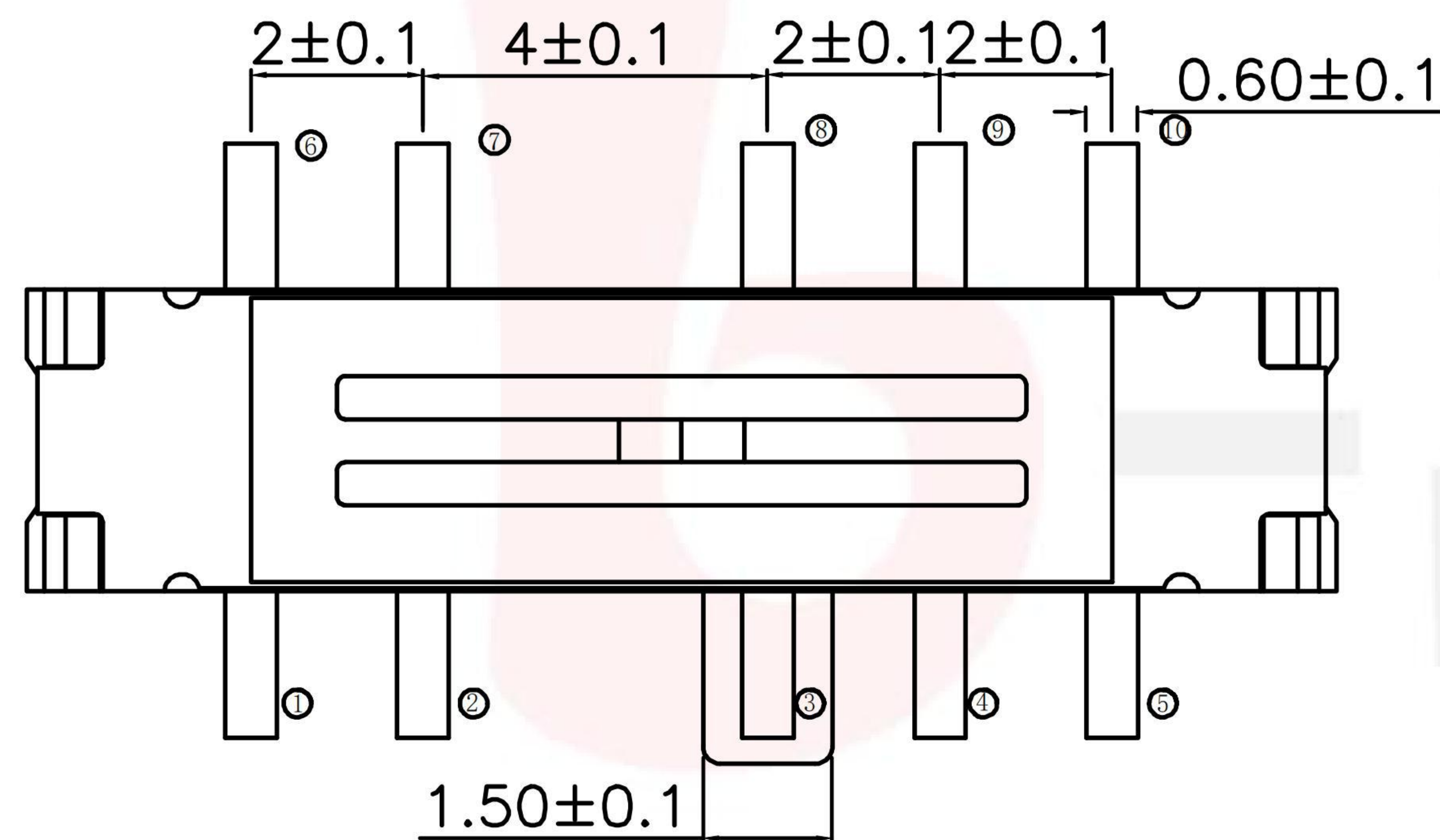

PCB PLERING PLAN

G-Switch Specification:

Electrical Specifications: DC 12V 0.5A DC 6V 1.0A
Contact Resistance : 100mΩMAX
Insulation Resistance: 100M ohm 100V DC
Withstand Voltage: AC 250V for 1 min
Ambient Temperature: -20°C~+70°C
Relative Humidity: (40°C)≤85%
Reflow soldering: 250°C MAX
Life: 10,000 times

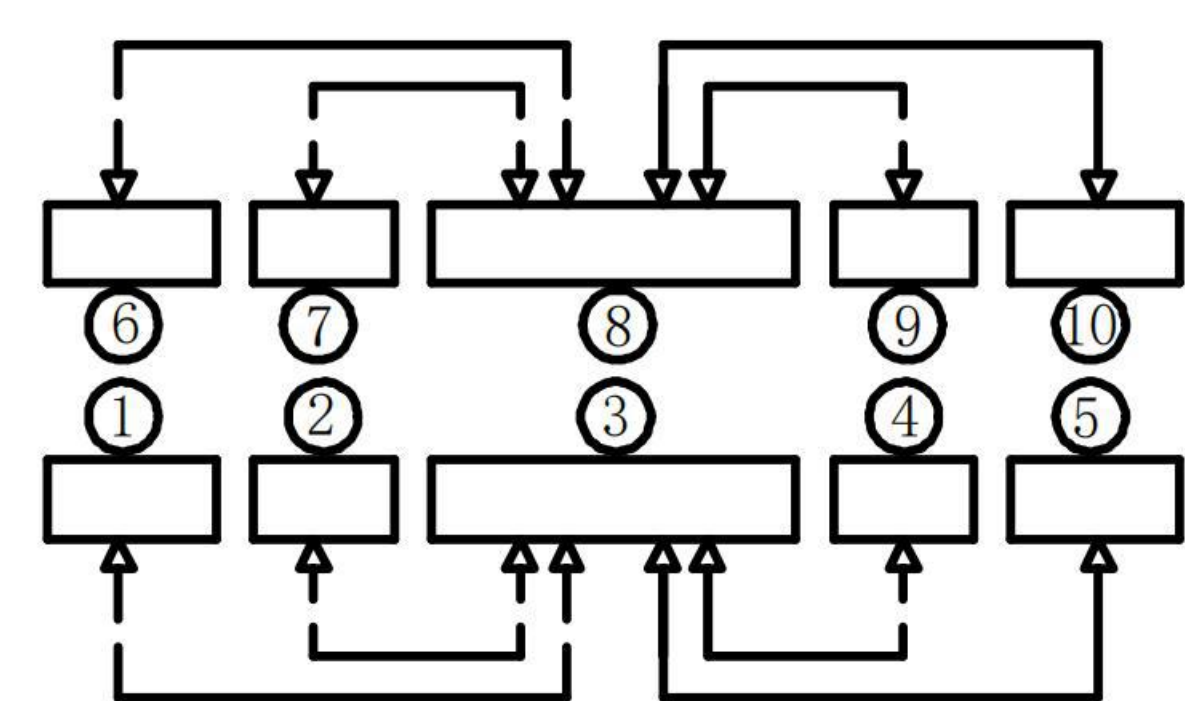

CIRCUIT DIAGRAM



RoHS
Compliant
2002/95/EC



G-Switch Electronic (HongKong) CO.,Ltd.

Unless otherwise specified, Tolerance:
X. ±0.30
X.x ±0.20
X.xx ±0.15
X.xxx ±0.10
Angles ±3°

DESIGN FengFengChen DATE 2019.05.29
CHECKED DATE
APPROVED DATE
<http://www.dg-switch.com>
TEL:0769-82388879

Molde code:
MK-42C10-GXXX
REV.: X1 SCALE: 4:1 UNIT: mm
SIZE: A4 SHEET: 1/1