

1  
2  
3  
4  
5

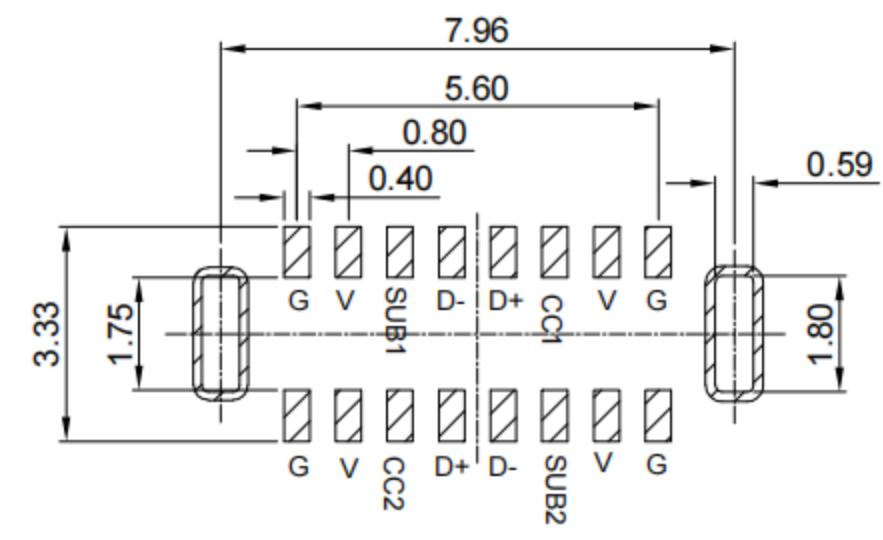

RECOMMENDED PCB LAYOUT  
TOLERANCE: ±0.05

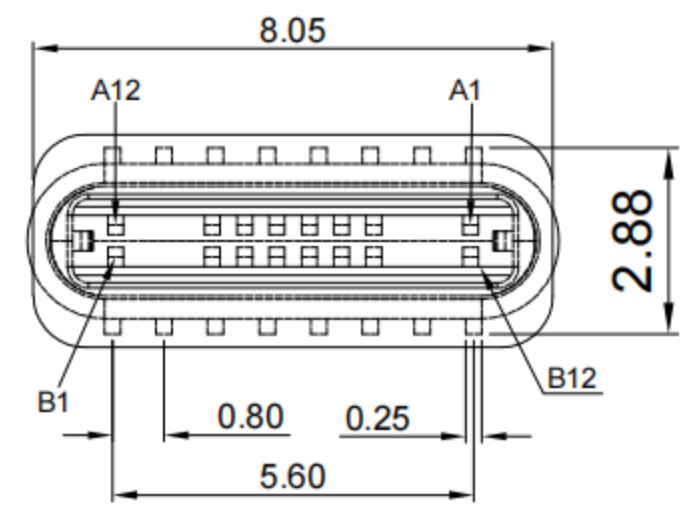
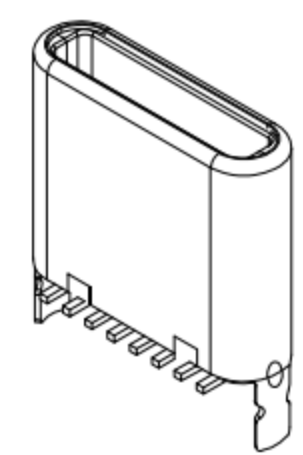
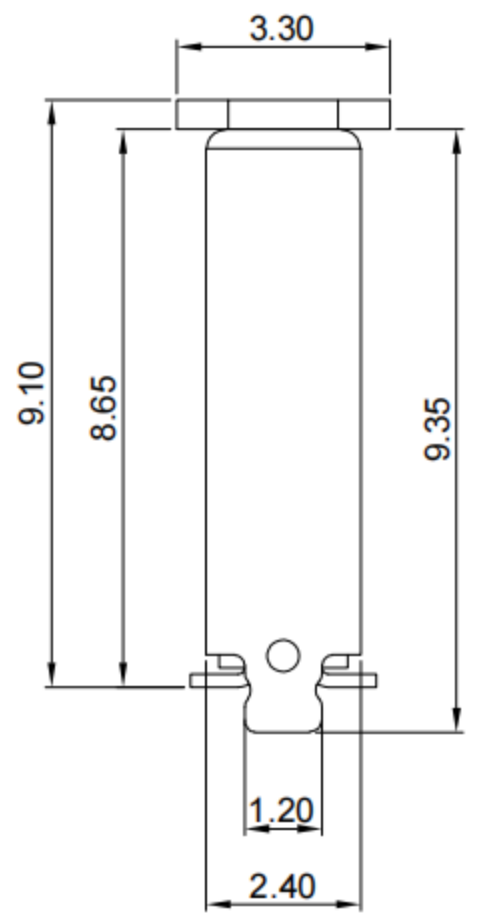
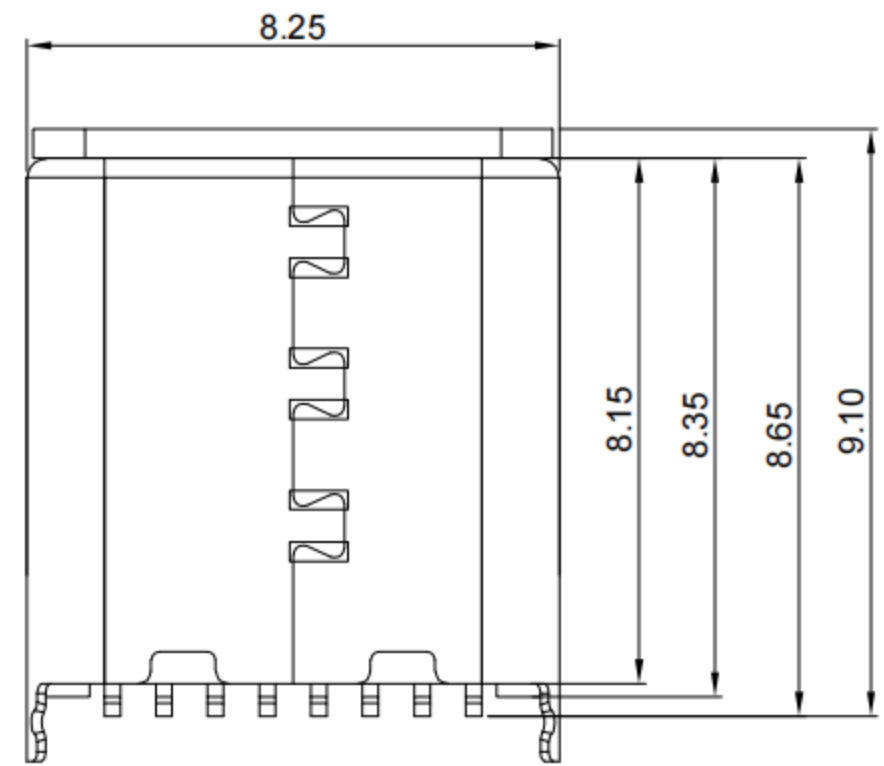

- G-Switch USB-C Specification:**
- Current rated: 3A on vbus/1.25A on vconn/0.25A on other  
Voltage rating: 5V AC
  - Withstanding voltage: 100V AC/minute
  - Contact resistance: 40mΩ Max
  - Insulation resistance: 100MΩ Min
  - Operating temperature: -40°C ~ +85°C
  - Mating force: 5N~20N
  - Unmating force: 8N~20N
  - Durability cycle: 10,000 cycles

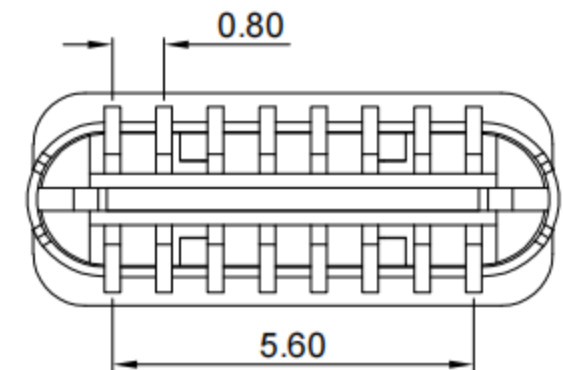

A12	A11	A10	A9	A8	A7	A6	A5	A4	A3	A2	A1
GND			VBUS	SBU1	D-	D+	CC1	VBUS			GND
First			First	Second	Second	Second	Second	First			First

B1	B2	B3	B4	B5	B6	B7	B8	B9	B10	B11	B12
GND			VBUS	VCONN	D+	D-	SBU2	VBUS			GND
First			First	Second	Second	Second	Second	First			First

4	TERMINALS	COPPER ALLOY	Au PLATING ON CONTACT AREA
3	LATCH	STAINLESS STEEL	---
2	HOUSING	HIGH TEMPERATURE PLASTIC	BLACK UL 94 V-0
1	SHELL	STAINLESS STEEL	Ni PLATED
NO.	NAME	DESCRIPTION	REMARKS



SCALE: 4:1	UNIT: mm	Title: Vertical Type-c 16P Plug	
SIZE: A4		SMT H=8.65mm	
Unless otherwise General Tolerance:		Molde Code: GT-USB-8019B	
X.	/	DRAWN	CHECKED
X.x	±0.30	APPROVED	DATE
X.xx	±0.20	Xia	Chen
X.xxx	±0.10	Chen	2023.02.01
X*	±5°		



REV: A0 SHEET: 1/1