

**G-Switch USB-C Specification:**

1. Current rated: 3A on vbus/1.25A on vconn/0.25A on other
2. Voltage rating: 5V AC
3. Withstanding voltage: 100V AC/minute
4. Contact resistance: 40mΩ Max
5. Insulation resistance: 100MΩ Min
6. Operating temperature: -40°C ~ +85°C
7. Mating force: 5N~20N
8. Unmating force: 8N~20N
9. Durability cycle: 10,000 cycles

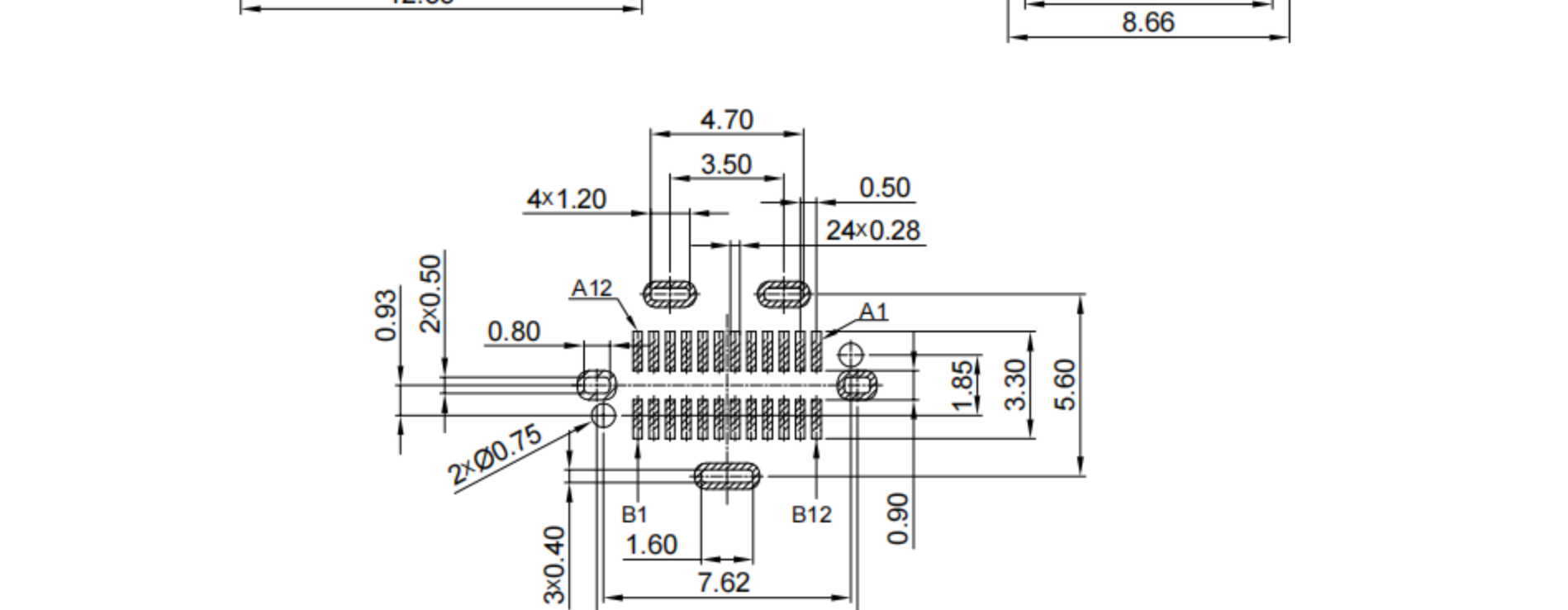
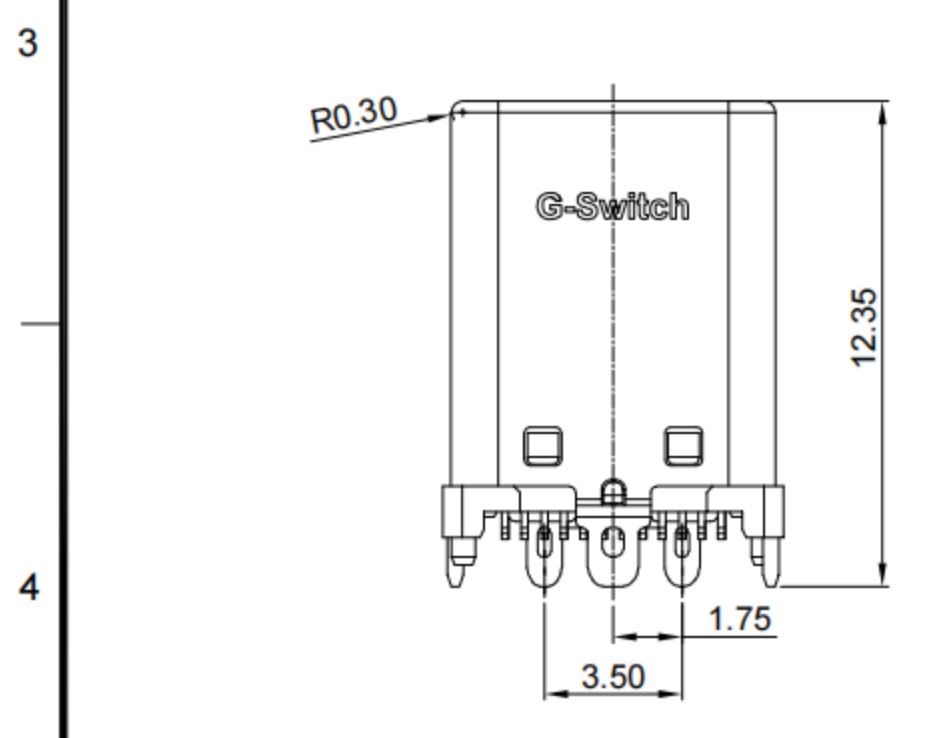

A12	A11	A10	A9	A8	A7	A6	A5	A4	A3	A2	A1
GND	RX2+	RX2-	VBUS	SBU1	D-	D+	CC1	VBUS	TX1-	TX1+	GND
First	Second	Second	First	Second	Second	Second	Second	First	Second	Second	First

B1	B2	B3	B4	B5	B6	B7	B8	B9	B10	B11	B12
GND	TX2+	TX2-	VBUS	VCONN	D+	D-	SBU2	VBUS	RX1-	RX1+	GND
First	Second	Second	First	Second	Second	Second	Second	First	Second	Second	First

6	COVER	HIGH TEMPERATURE PLASTIC	BLACK UL 94 V-0
5	SPRING	STAINLESS STEEL	NI PLATED
4	TERMINALS	COPPER ALLOY	Au PLATING ON CONTACT AREA
3	LATCH	STAINLESS STEEL	---
2	HOUSING	HIGH TEMPERATURE PLASTIC	BLACK UL 94 V-0
1	SHELL	STAINLESS STEEL	NI PLATED
NO.	NAME	DESCRIPTION	REMARKS

**RECOMMENDED PCB LAYOUT**  
TOLERANCE: ±0.05

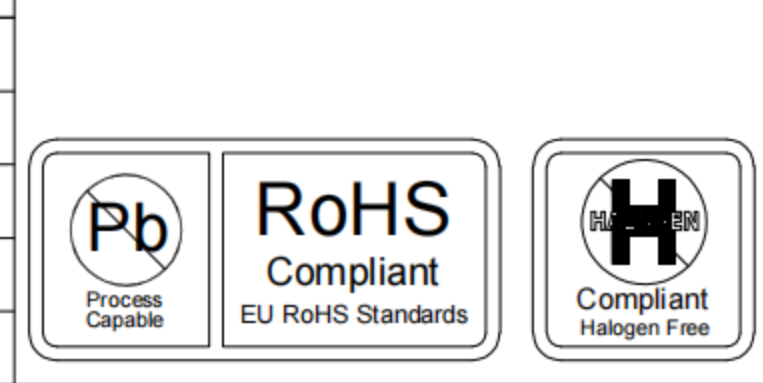

SCALE: 4:1	UNIT: mm	Title: Vertical Type-c 24P Plug	
SIZE: A4		SMT H=11.1mm	
Unless otherwise General Tolerance:		Molde Code: GT-USB-8018B	
X.	±0.30	DRAWN	CHECKED
X.x	±0.20	APPROVED	DATE
X.xx	±0.15	Xia	Chen
X.xxx	±0.10	Chen	2023.02.01
X*	±5°		

品赞科技®  
**b-Switch**  
www.dg-switch.com

REV: A0 SHEET: 1/1