

RECOMMENDED ASSEMBLY DRAWING

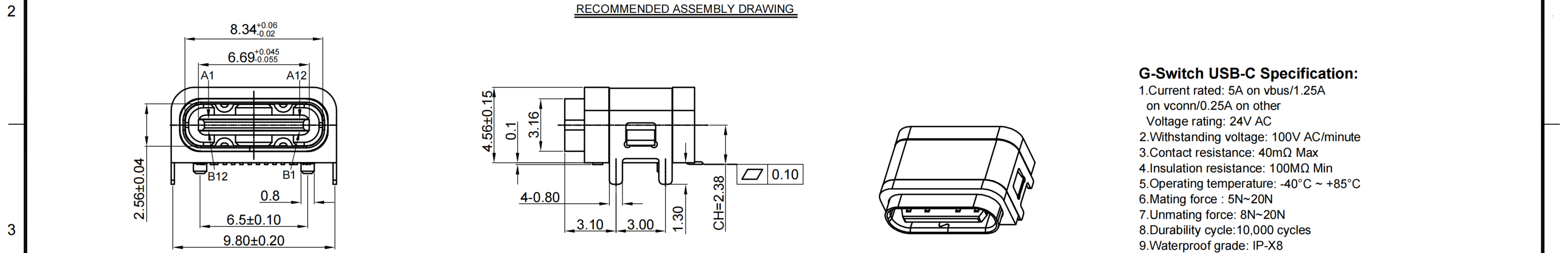

G-Switch USB-C Specification:

- 1.Current rated: 5A on vbus/1.25A on vconn/0.25A on other
- Voltage rating: 24V AC
- 2.Withstanding voltage: 100V AC/minute
- 3.Contact resistance: 40mΩ Max
- 4.Insulation resistance: 100MΩ Min
- 5.Operating temperature: -40°C ~ +85°C
- 6.Mating force : 5N~20N
- 7.Unmating force: 8N~20N
- 8.Durability cycle:10,000 cycles
- 9.Waterproof grade: IP-X8

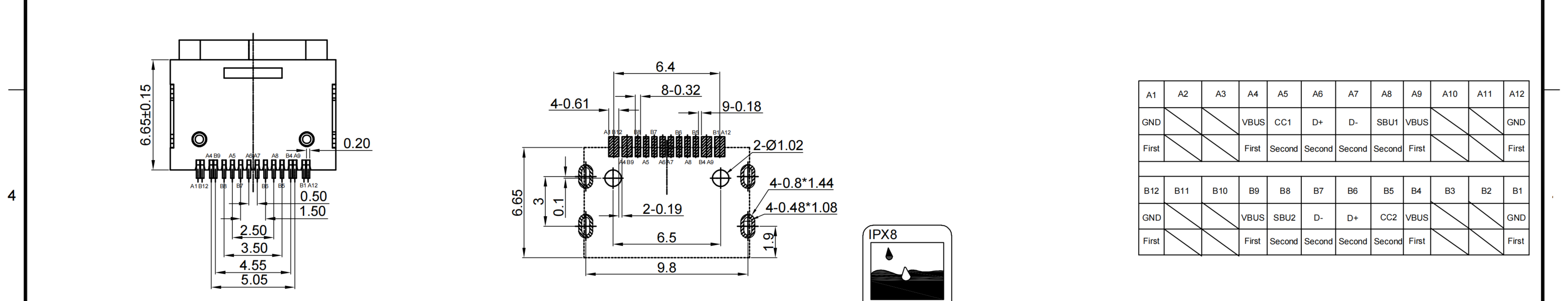

RECOMMENDED PCB LAYOUT
TOLERANCE:±0.05

A1	A2	A3	A4	A5	A6	A7	A8	A9	A10	A11	A12
GND			VBUS	CC1	D+	D-	SBU1	VBUS			GND
First			First	Second	Second	Second	Second	First			First

B12	B11	B10	B9	B8	B7	B6	B5	B4	B3	B2	B1
GND			VBUS	SBU2	D-	D+	CC2	VBUS			GND
First			First	Second	Second	Second	Second	First			First

1	SHELL	STAINLESS STEEL	NI PLATED
2	SHEATH	HIGH TEMPERATURE PLASTIC	Black UL 94 V-0
3	MID PLATE	STAINLESS STEEL	NI PLATED
4	HOUSING	HIGH TEMPERATURE PLASTIC	Black UL 94 V-0
5	TERMINALS	COPPER ALLOY	Au PLATING ON CONTACT AREA
6	WATERPROOF RING	SILICA GEL	Black UL 94 V-0
NO.	PARTS	MATERIAL	REMARKS

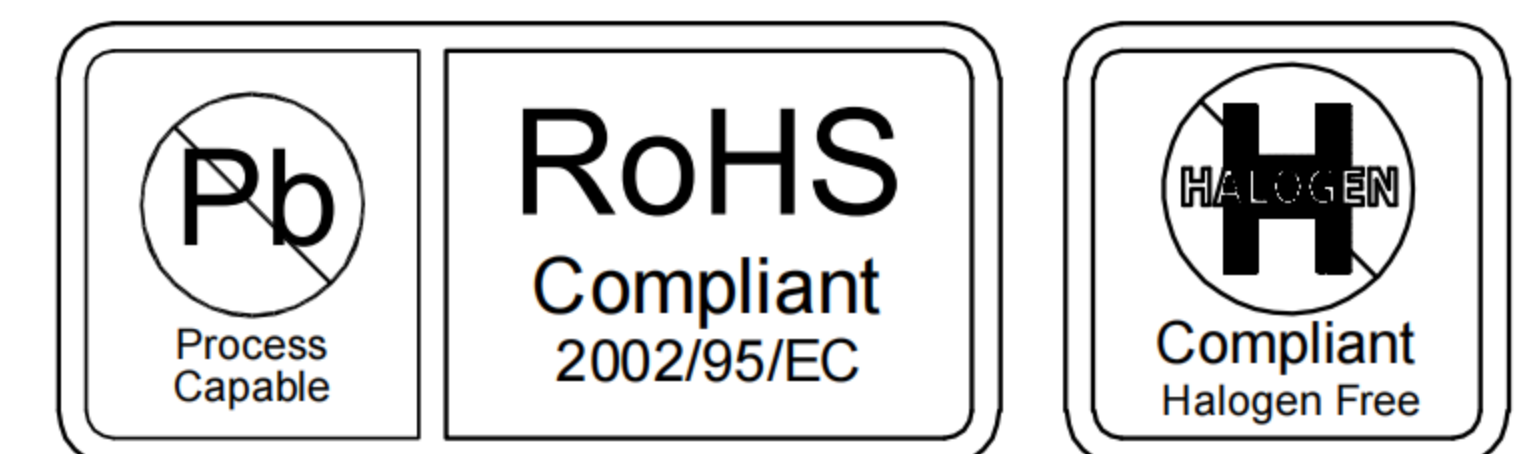

SCALE: 1:1	UNIT: mm	Title: Horizontal Type-c 16P Female SMT CH=2.38 L=7.85mm	
SIZE: A4		Title: Horizontal Type-c 16P Female SMT CH=2.38 L=7.85mm	
Unless otherwise General Tolerance:		Title: Horizontal Type-c 16P Female SMT CH=2.38 L=7.85mm	
X.	±0.20	Title: Horizontal Type-c 16P Female SMT CH=2.38 L=7.85mm	
X.x	±0.15	Title: Horizontal Type-c 16P Female SMT CH=2.38 L=7.85mm	
X.xx	±0.10	Title: Horizontal Type-c 16P Female SMT CH=2.38 L=7.85mm	
X.xxx	±0.05	Title: Horizontal Type-c 16P Female SMT CH=2.38 L=7.85mm	
Angles	±3°	Title: Horizontal Type-c 16P Female SMT CH=2.38 L=7.85mm	



MoIde Code: GT-USB-7070A01	DRAWN	CHECKED	APPROVED	DATE
	Xia	Chen	Chen	2023.02.01

REV: A0 SHEET: 1/1