

**G-Switch USB-C Specification:**

1. Current rated: 5A on vbus/1.25A on vconn/0.25A on other
2. Voltage rating: 24V AC
3. Withstanding voltage: 100V AC/minute
4. Contact resistance: 40mΩ Max
5. Insulation resistance: 100MΩ Min
6. Operating temperature: -40°C ~ +85°C
7. Mating force : 5N~20N
8. Unmating force: 8N~20N
9. Durability cycle: 10,000 cycles
10. Waterproof grade: IP-X7

A1	A2	A3	A4	A5	A6	A7	A8	A9	A10	A11	A12
GND			VBUS	CC1	D+	D-	SBU1	VBUS			GND
First			First	Second	Second	Second	Second	First			First
B12	B11	B10	B9	B8	B7	B6	B5	B4	B3	B2	B1
GND			VBUS	SBU2	D-	D+	CC2	VBUS			GND
First			First	Second	Second	Second	Second	First			First

1	RUBBER RING	SILICA GEL	Black
2	SHELL	ZINC ALLOG	Ni Plated
3	MID-PLATE	STAINLESS	Ni Plated
4	TERMINALS	COPPER ALLOY	Au Plating On Contact Area
5	HOUSING	HIGH TEMPERATURE PLASTIC	Black UL 94 V-0
NO.	PARTS	MATERIAL	REMARKS

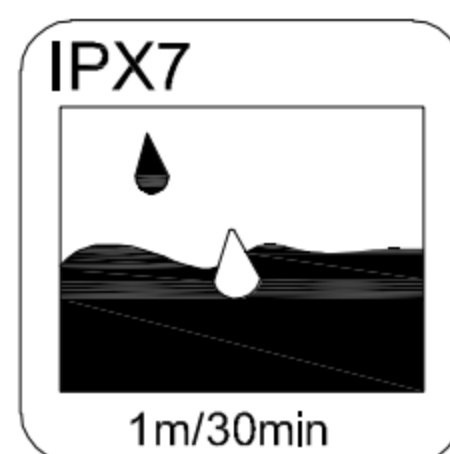

SCALE: 1:1 UNIT: mm  
 SIZE: A4

Unless otherwise  
 General Tolerance:  
 X. ±0.25  
 X.x ±0.20  
 X.xx ±0.15  
 X.xxx ±0.10  
 X° ±5°

Title: Horizontal Type-c 16P Female  
 SMT CH=1.68 L=5.4mm

Molde Code: GT-USB-7022A

DRAWN	CHECKED	APPROVED	DATE
Xia	Chen	Chen	2023.02.01



REV: A0 SHEET: 1/1



A

B

C

D

E

1

1

2

2

3

3

4

4

5

5

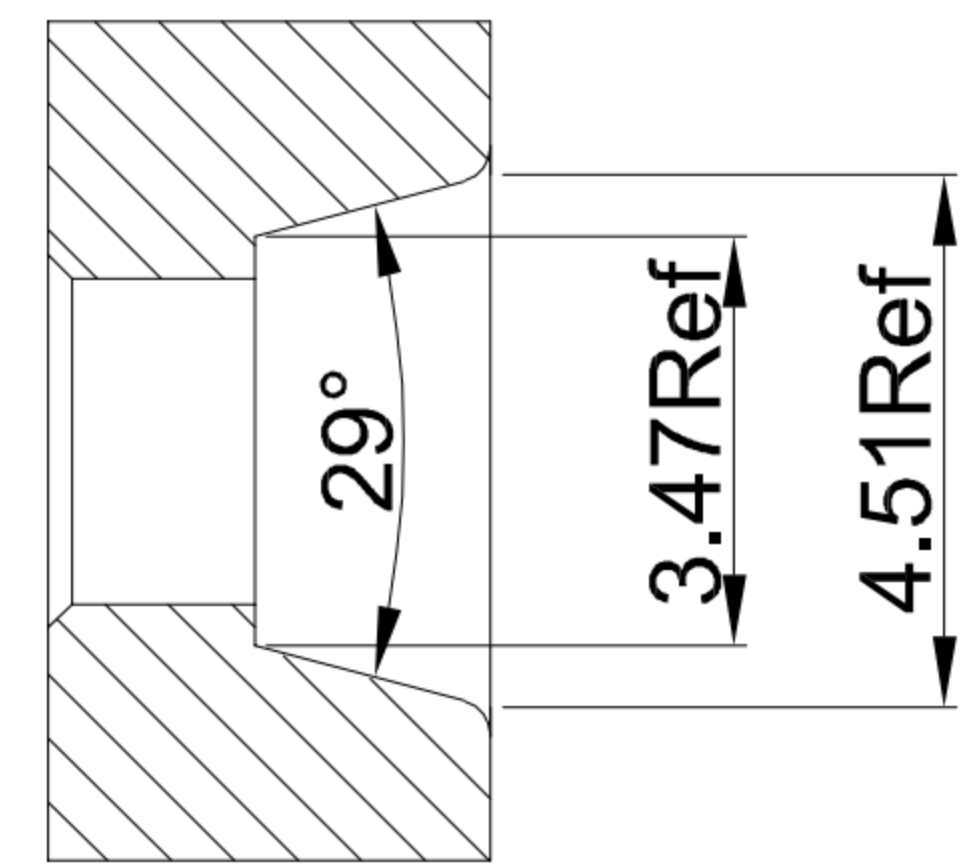

SECTION B-B

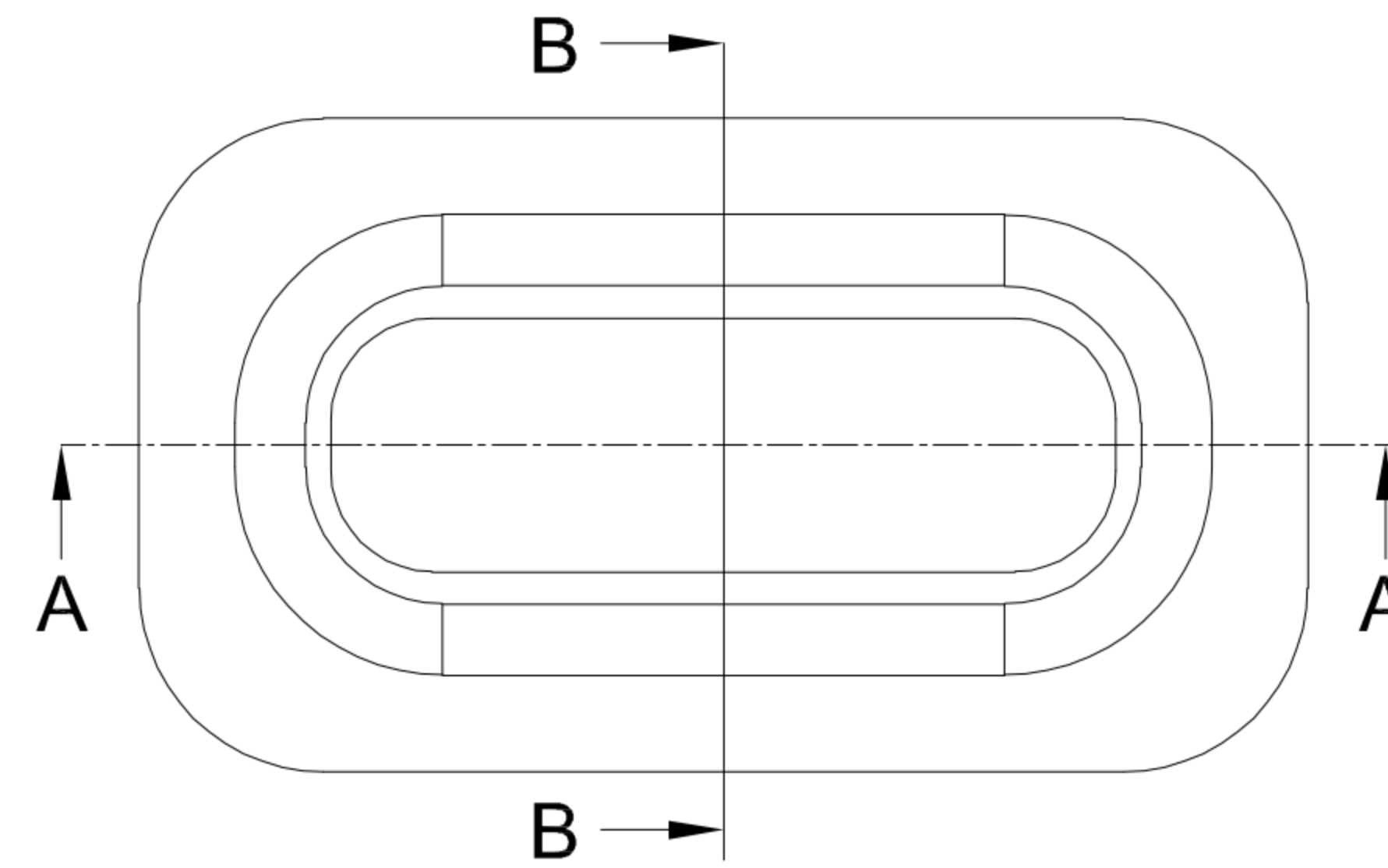

SECTION A-A

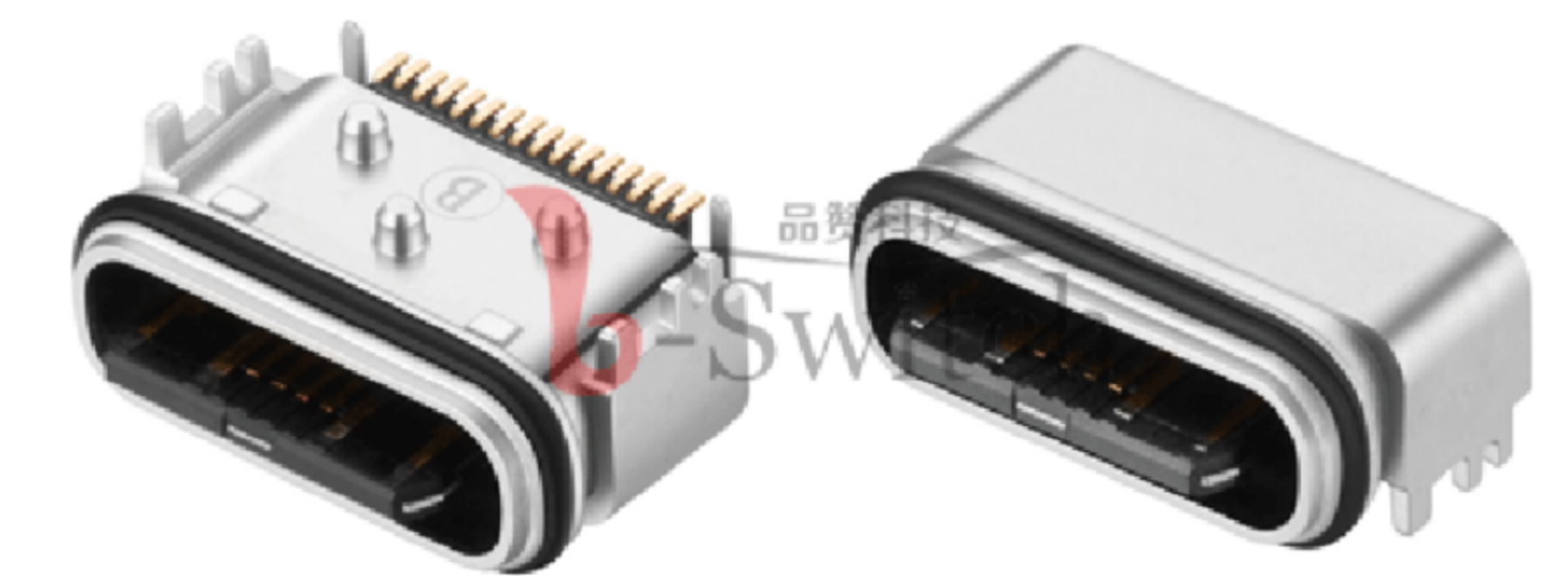
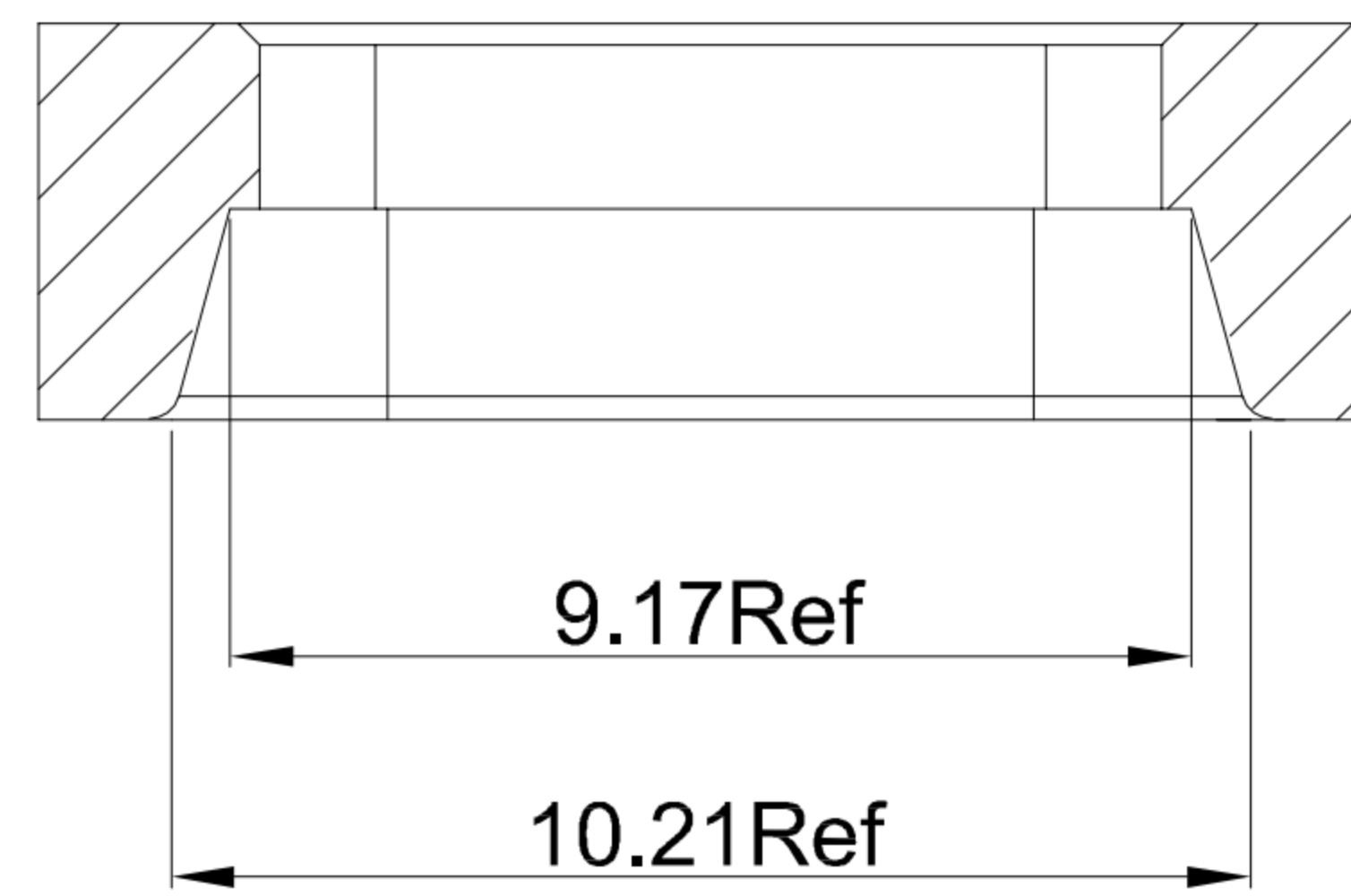
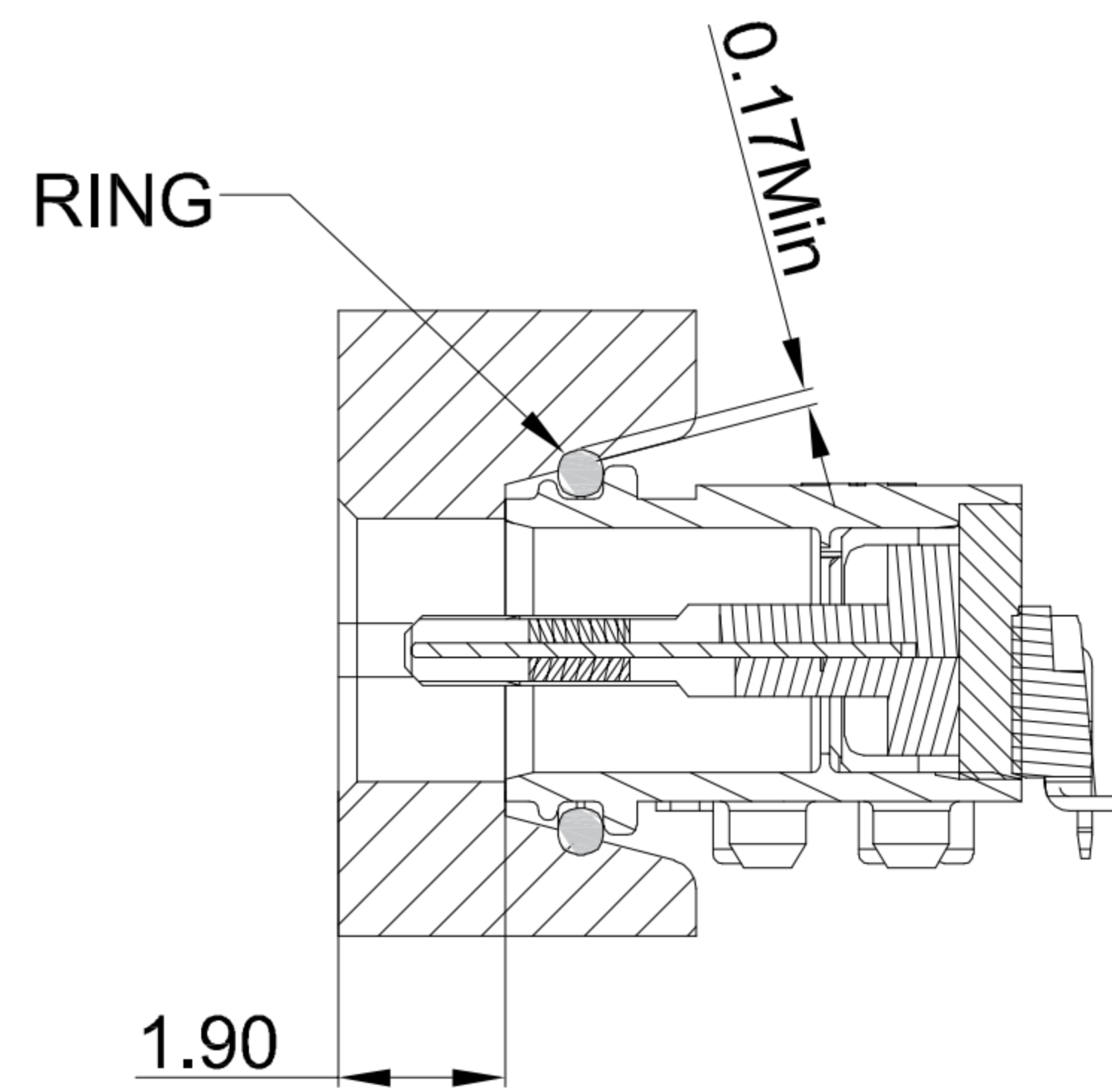

**G-Switch USB-C Specification:**

- 1.Current rated: 5A on vbus/1.25A on vconn/0.25A on other  
Voltage rating: 24V AC
- 2.Withstanding voltage: 100V AC/minute
- 3.Contact resistance: 40mΩ Max
- 4.Insulation resistance: 100MΩ Min
- 5.Operating temperature: -40°C ~ +85°C
- 6.Mating force : 5N~20N
- 7.Unmating force: 8N~20N
- 8.Durability cycle:10,000 cycles
- 9.Waterproof grade: IP-X7

A1	A2	A3	A4	A5	A6	A7	A8	A9	A10	A11	A12
GND			VBUS	CC1	D+	D-	SBU1	VBUS			GND
First			First	Second	Second	Second	Second	First			First
B12	B11	B10	B9	B8	B7	B6	B5	B4	B3	B2	B1
GND			VBUS	SBU2	D-	D+	CC2	VBUS			GND
First			First	Second	Second	Second	Second	First			First

SCALE: 1:1 UNIT: mm

SIZE: A4

Title: Horizontal Type-c 16P Female  
SMT CH=1.68 L=5.4mm

Molde Code: GT-USB-7022A

Unless otherwise  
General Tolerance:

X.	±0.25
X.x	±0.20
X.xx	±0.15
X.xxx	±0.10
X°	±5°

DRAWN	CHECKED	APPROVED	DATE
-------	---------	----------	------

Xia	Chen	Chen	2023.02.01
-----	------	------	------------



REV: A0 SHEET: 1/1

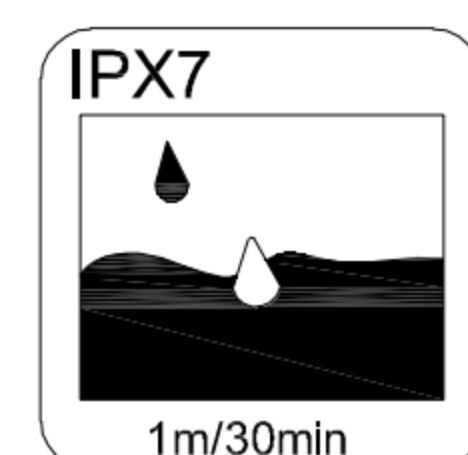

A

B

C

D

E