

A

B

C

D

E

1

1

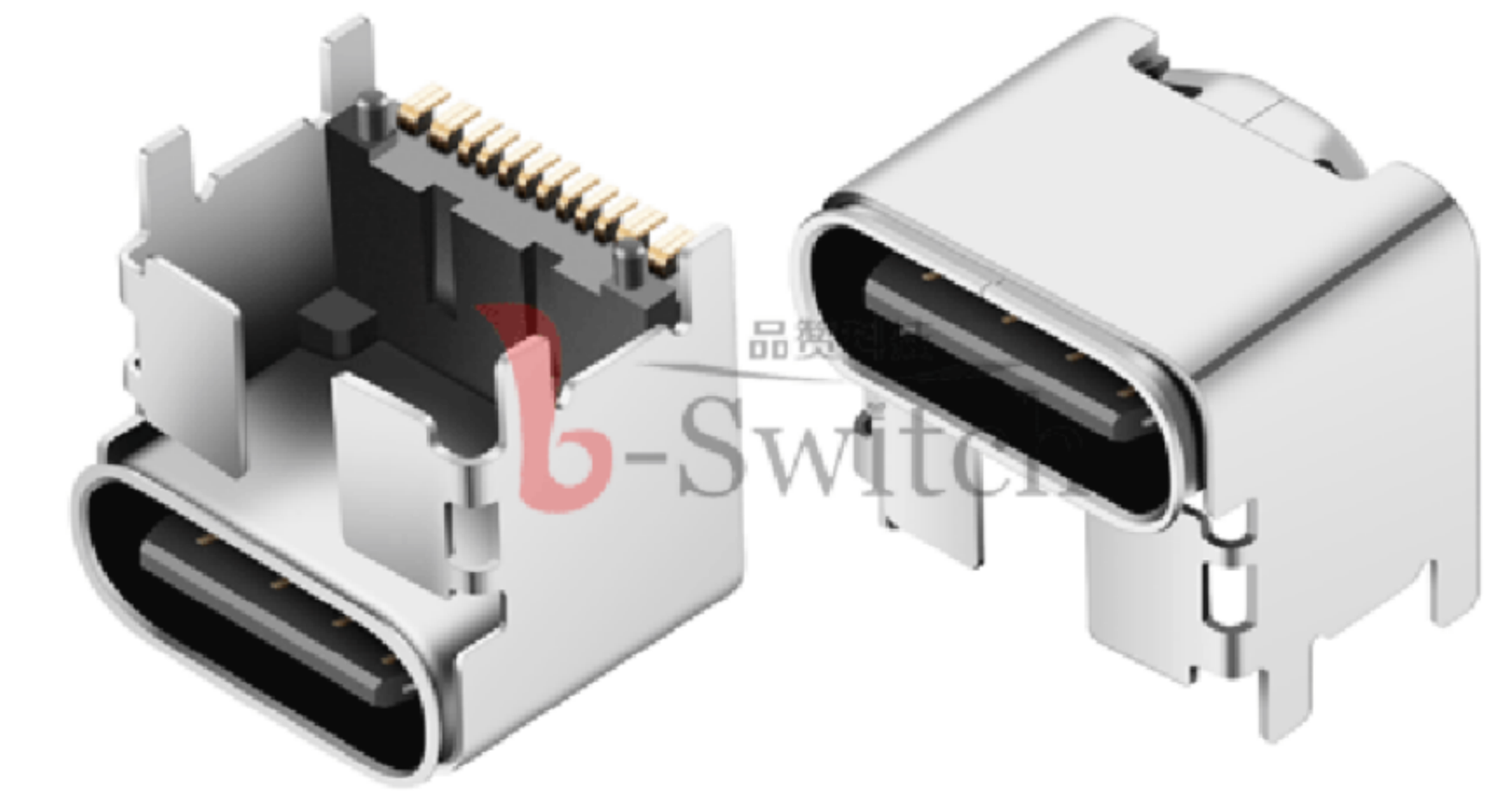
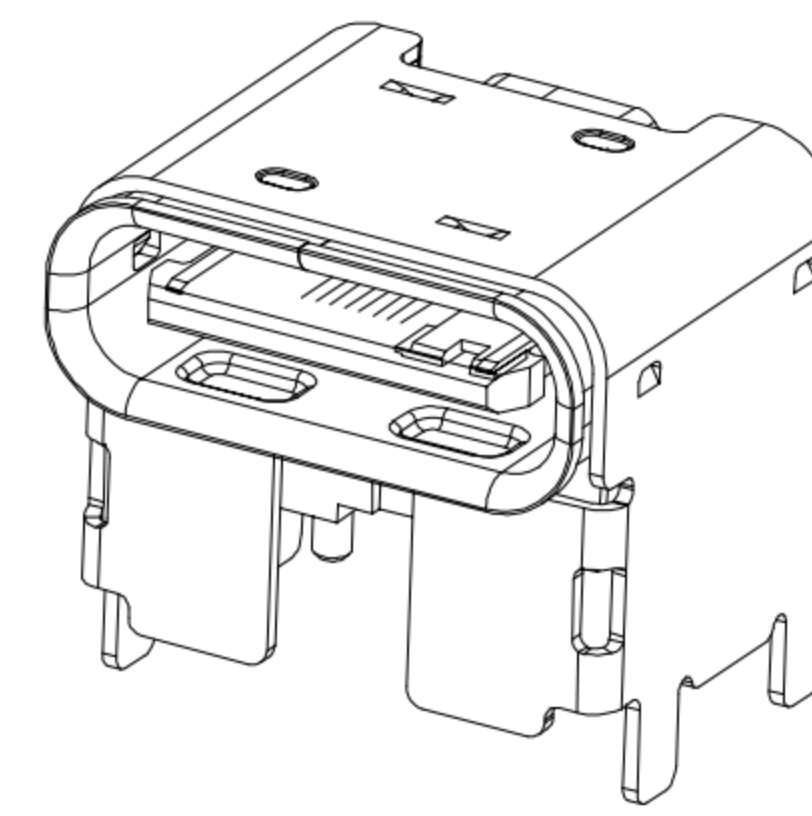
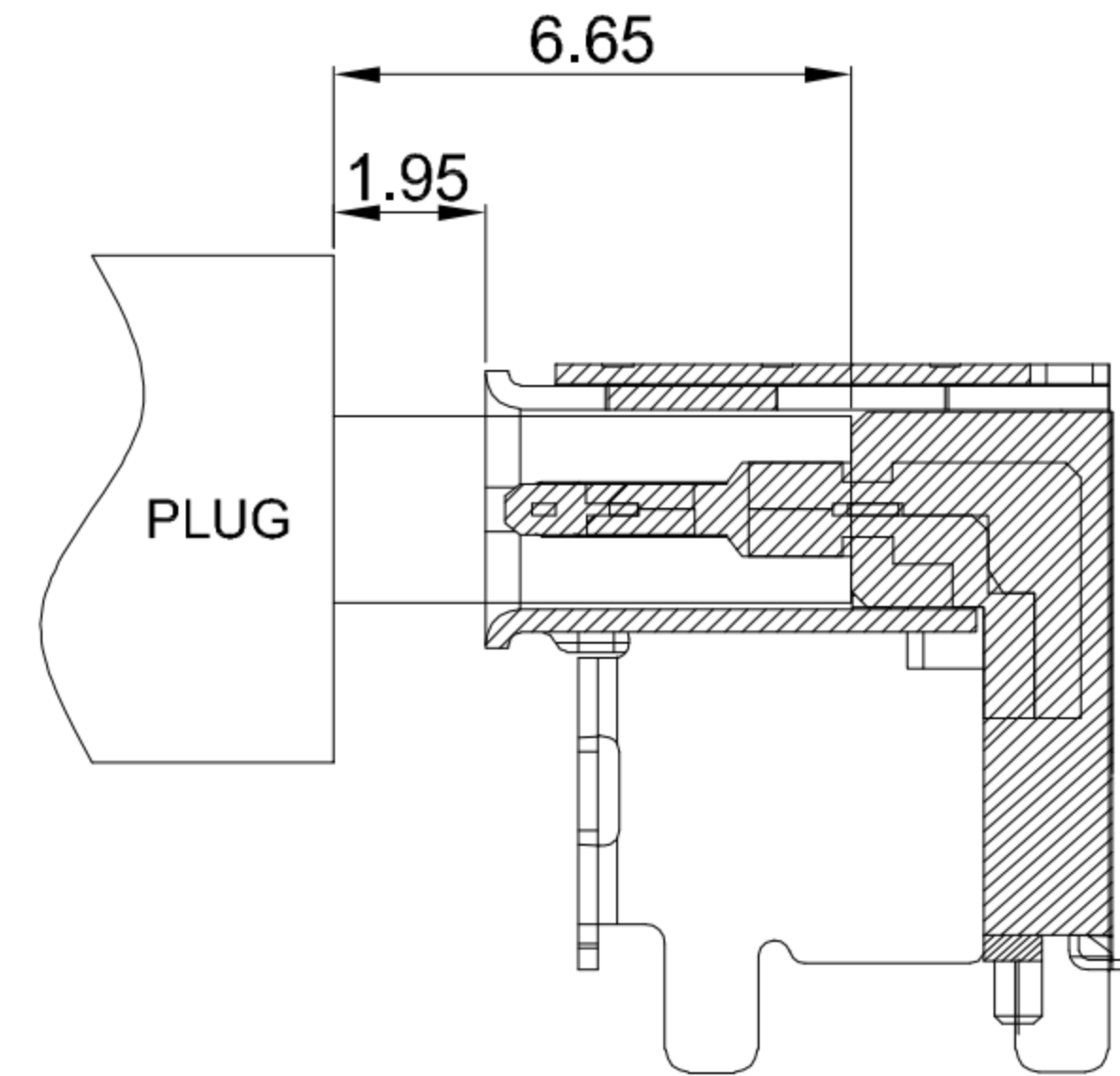
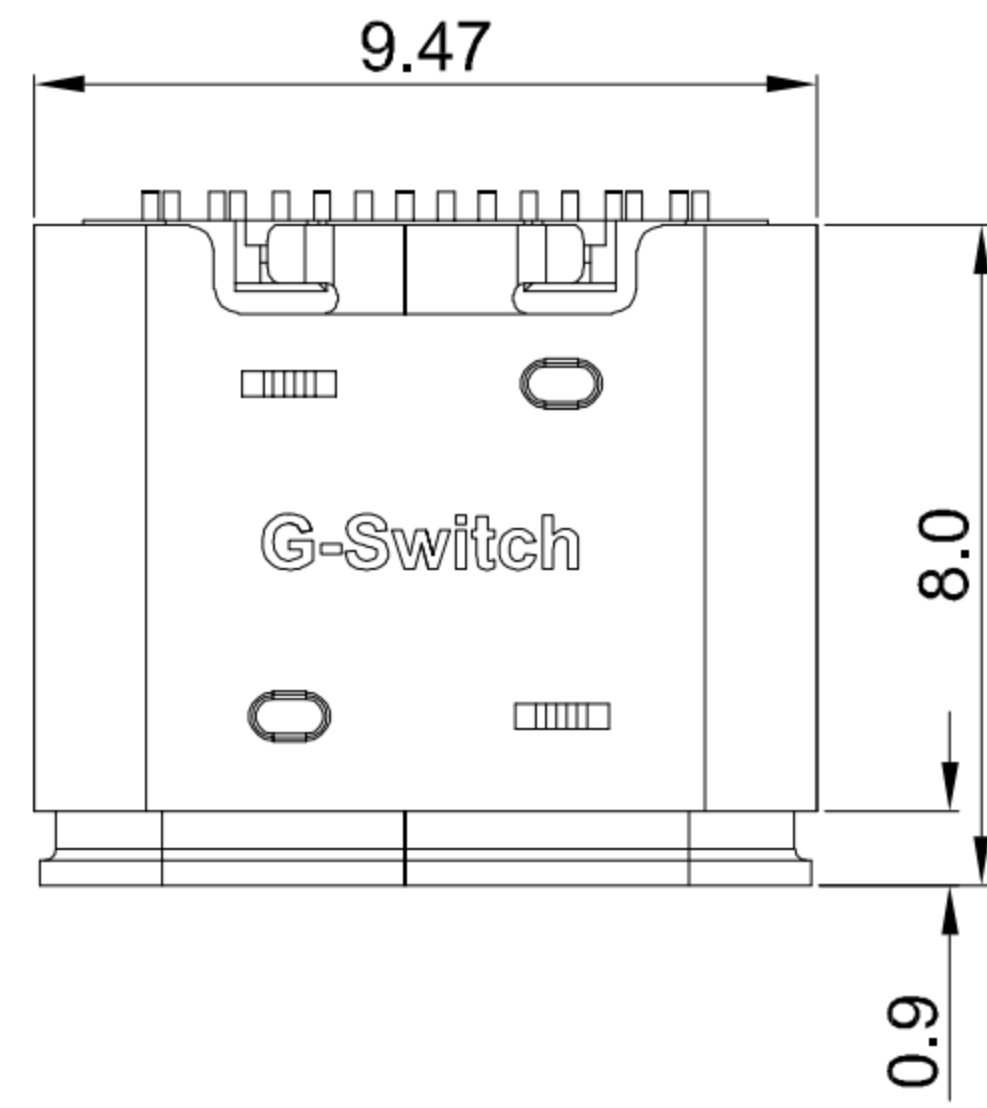

2

2

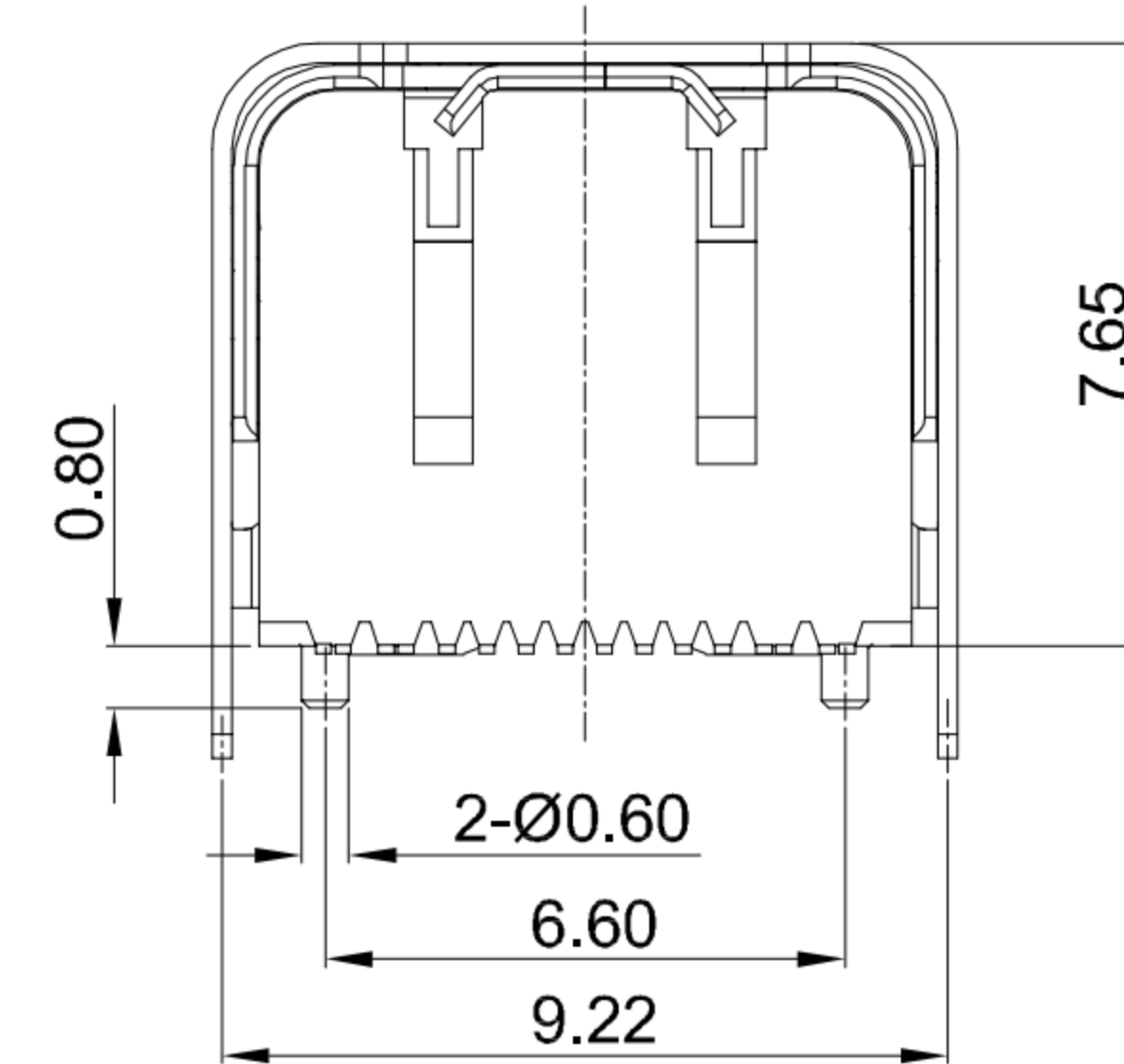
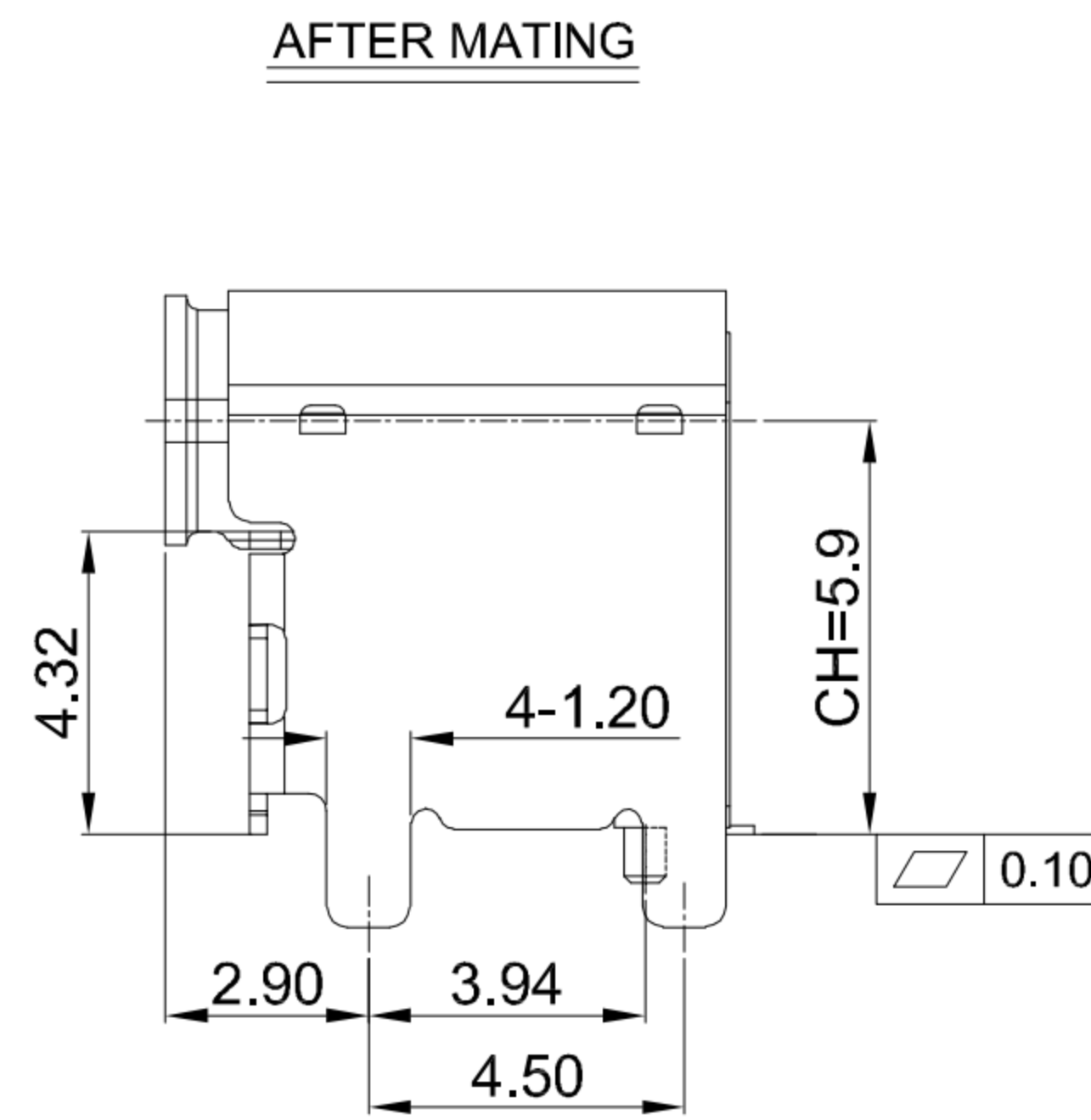
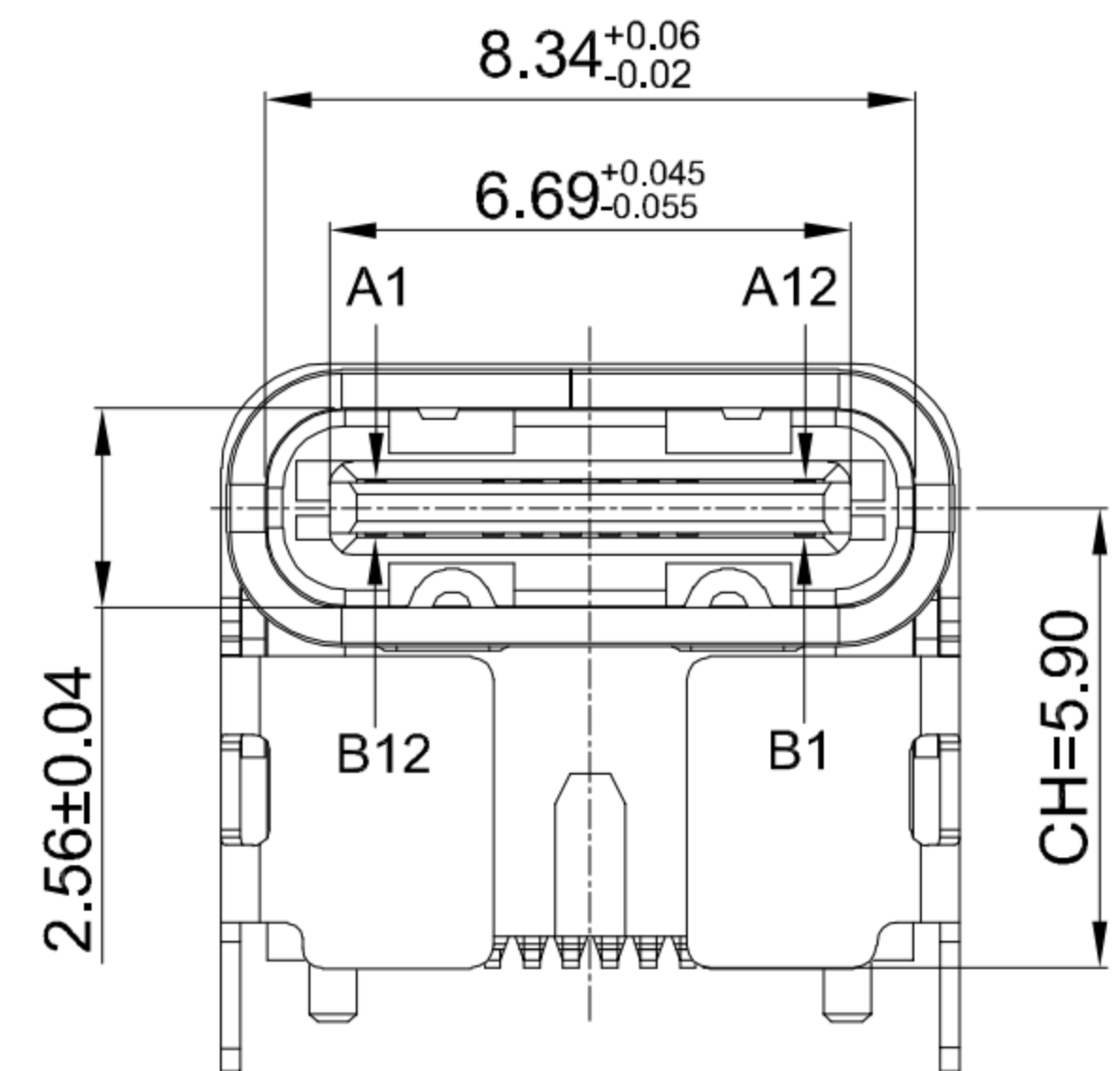

**G-Switch USB-C Specification:**

1. Current rated: 5A on vbus/1.25A on vconn/0.25A on other
- Voltage rating: 24V AC
2. Withstanding voltage: 100V AC/minute
3. Contact resistance: 40mΩ Max
4. Insulation resistance: 100MΩ Min
5. Operating temperature: -40°C ~ +85°C
6. Mating force: 5N~20N
7. Unmating force: 8N~20N
8. Durability cycle: 10,000 cycles

3

3

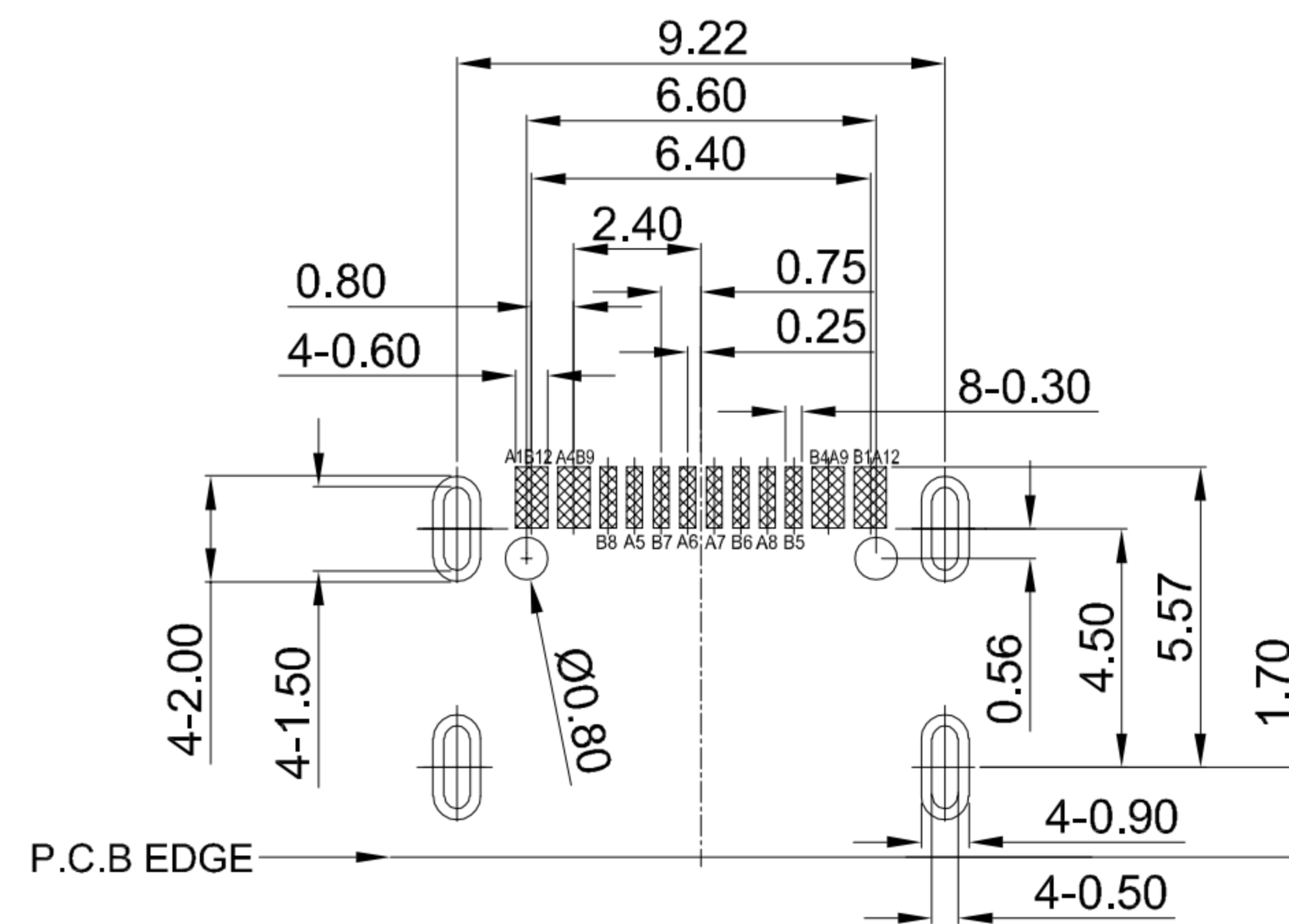
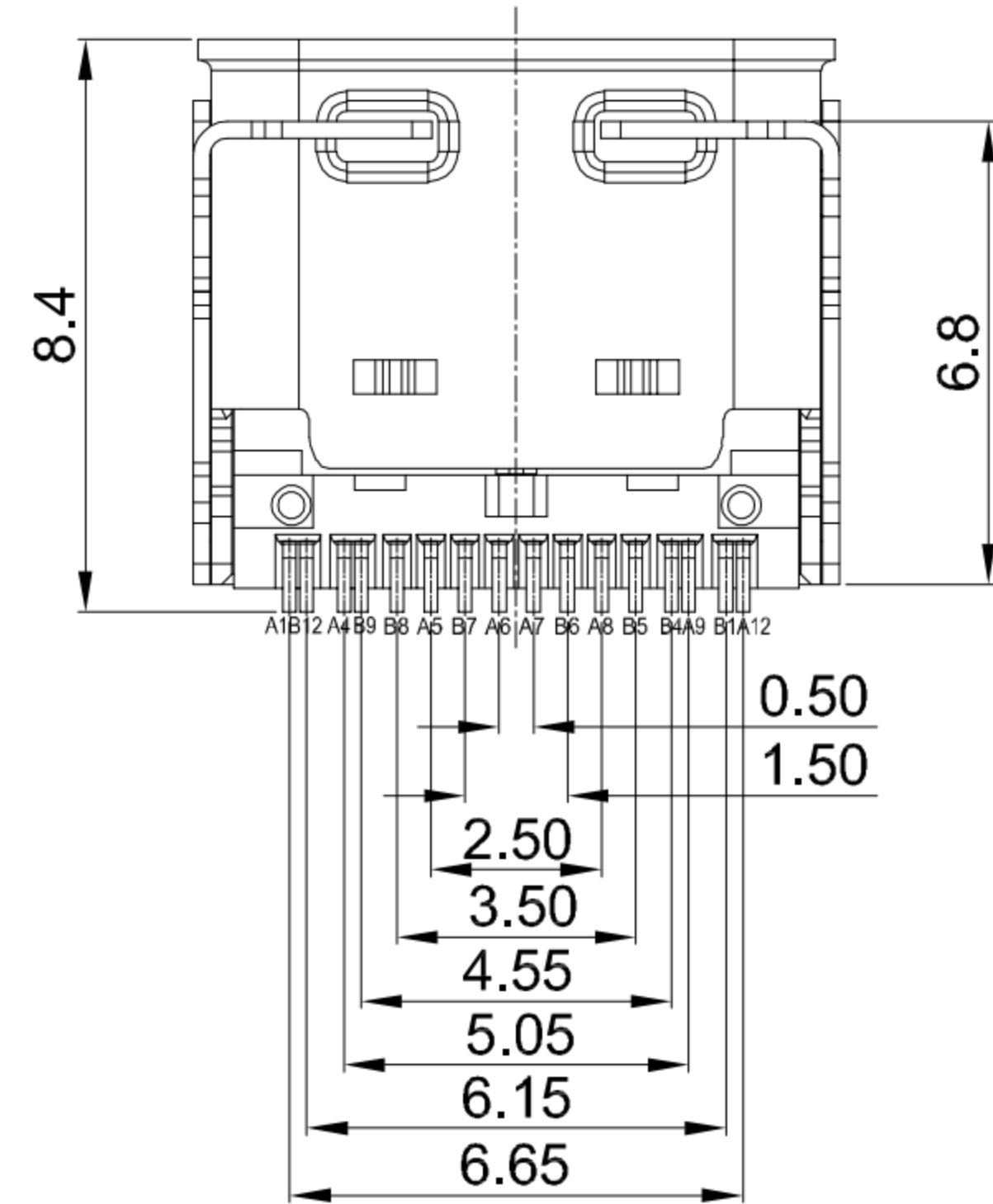

RECOMMENDED PCB LAYOUT  
TOLERANCE: ±0.05

A1	A2	A3	A4	A5	A6	A7	A8	A9	A10	A11	A12
GND			VBUS	CC1	D+	D-	SBU1	VBUS			GND
First			First	Second	Second	Second	Second	First			First
B12	B11	B10	B9	B8	B7	B6	B5	B4	B3	B2	B1
GND			VBUS	SBU2	D-	D+	CC2	VBUS			GND
First			First	Second	Second	Second	Second	First			First

4

4

1	HOUSING	HIGH TEMPERATURE PLASTIC	Black UL 94 V-0
2	CONTACT	COPPER ALLOY	Au PLATING ON CONTACT AREA
3	SHIELDING PLATE	STAINLESS STEEL	CLEAN
4	INNER SHELL	STAINLESS STEEL	NI PLATED
5	OUTER SHELL	STAINLESS STEEL	NI PLATED
NO.	PARTS	MATERIAL	REMARKS



SCALE: 1:1 UNIT: mm  
 SIZE: A4

Title: Horizontal Type-c 16P Female  
 Pad up 4.3 CH=5.9 L=8.0mm

Unless otherwise  
 General Tolerance:  
 X. ±0.25  
 X.x ±0.20  
 X.xx ±0.15  
 X.xxx ±0.10  
 X° ±5°

Molde Code: GT-USB-7016A01

DRAWN	CHECKED	APPROVED	DATE
Xia	Chen	Chen	2023.02.01



REV: A0 SHEET: 1/1

5

5

A

B

C

D

E