

1

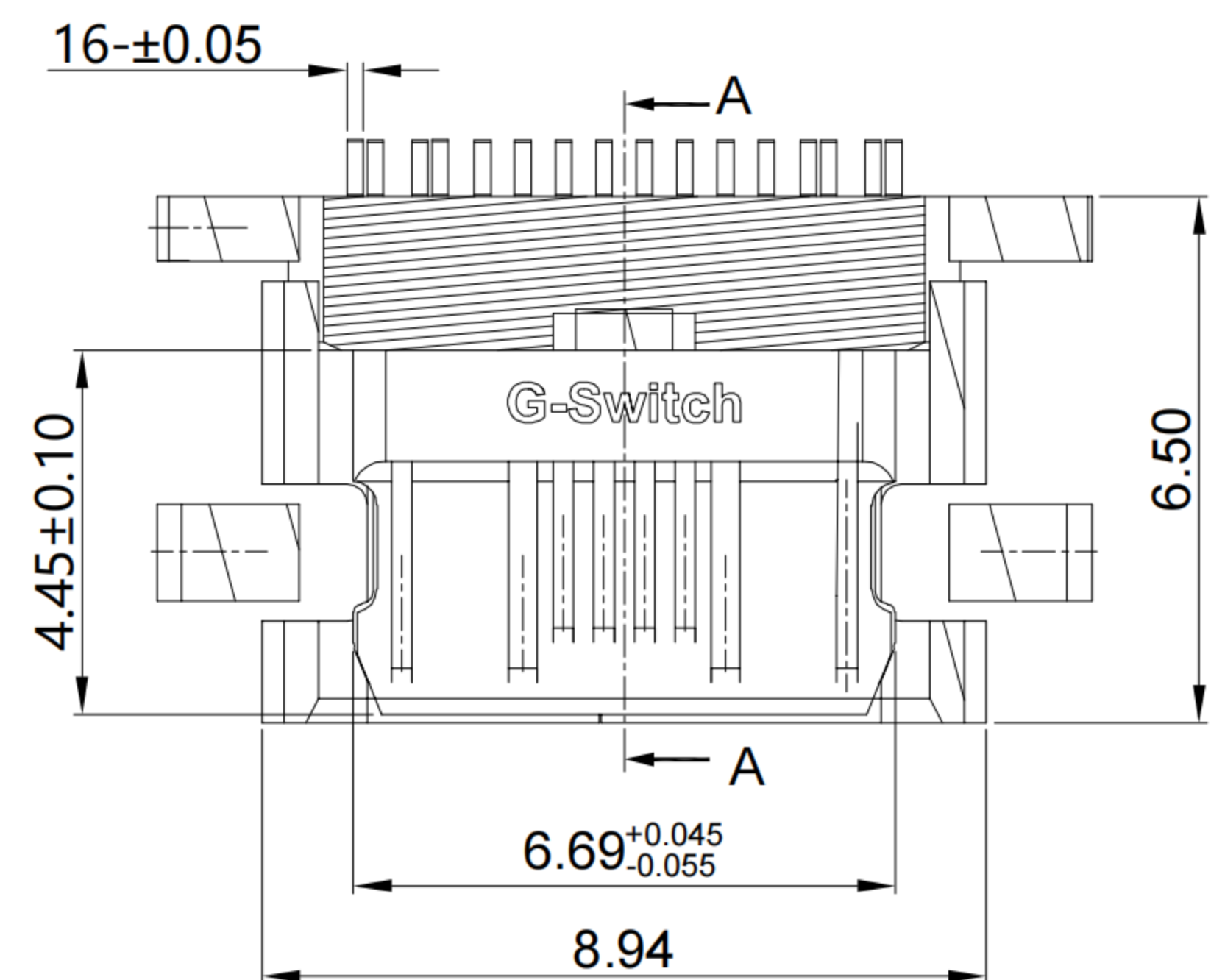

B

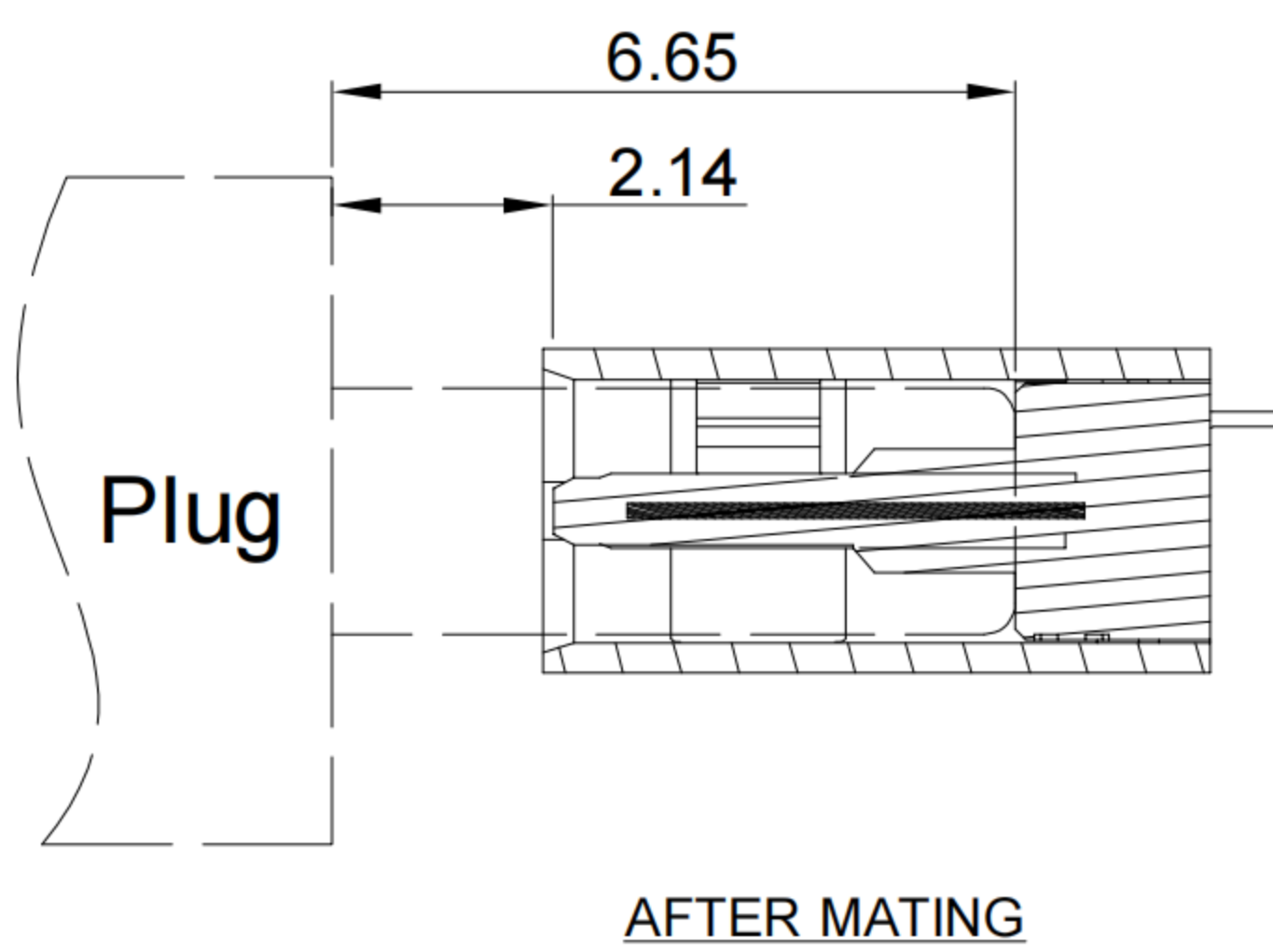

C

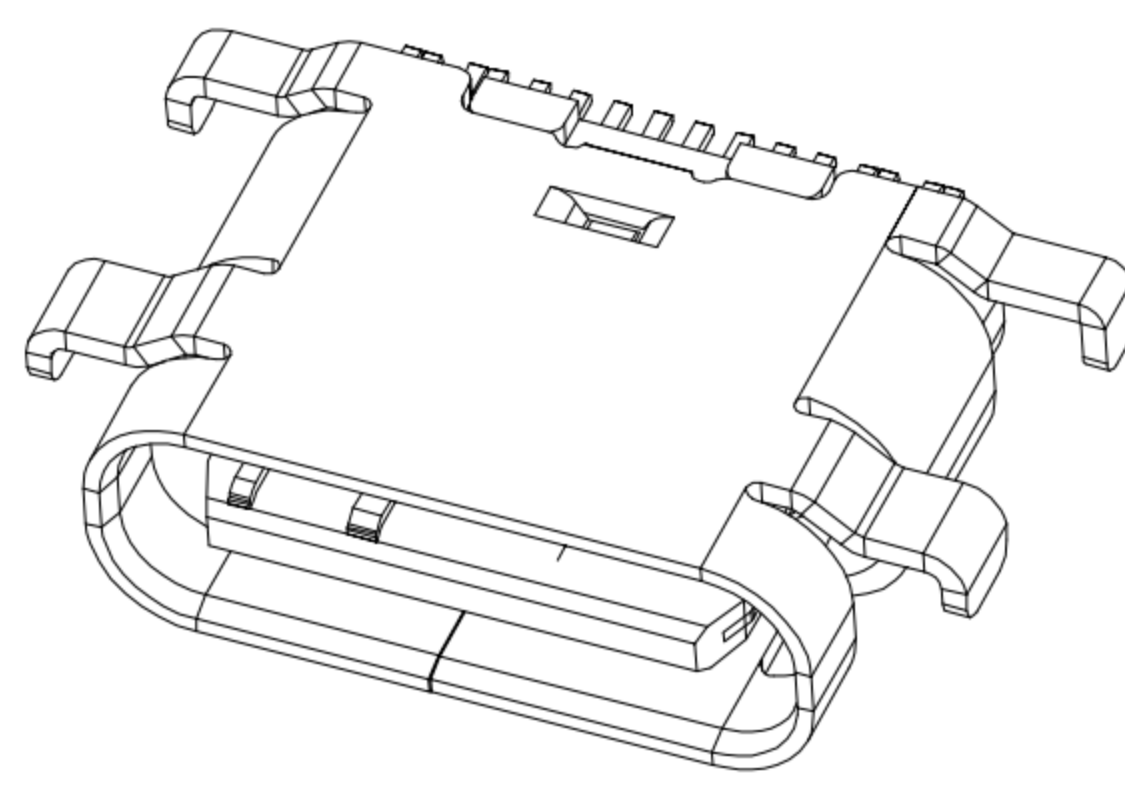

D

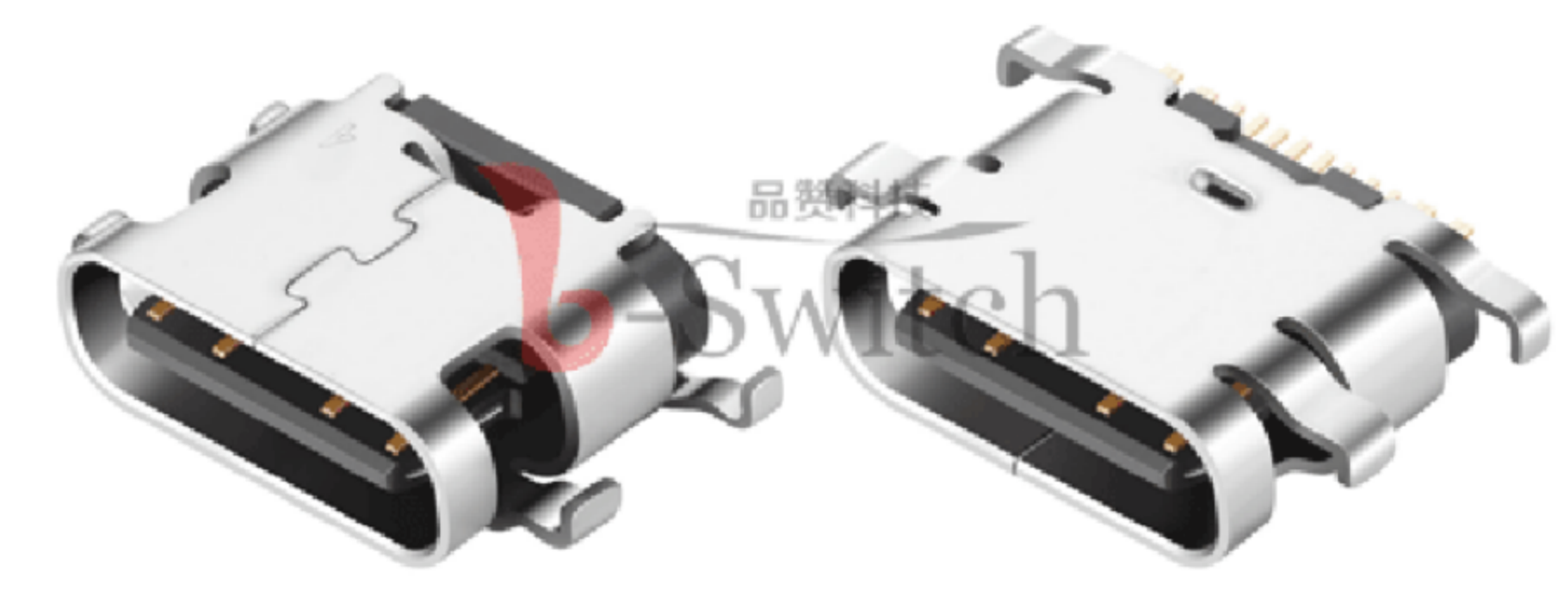

E

2

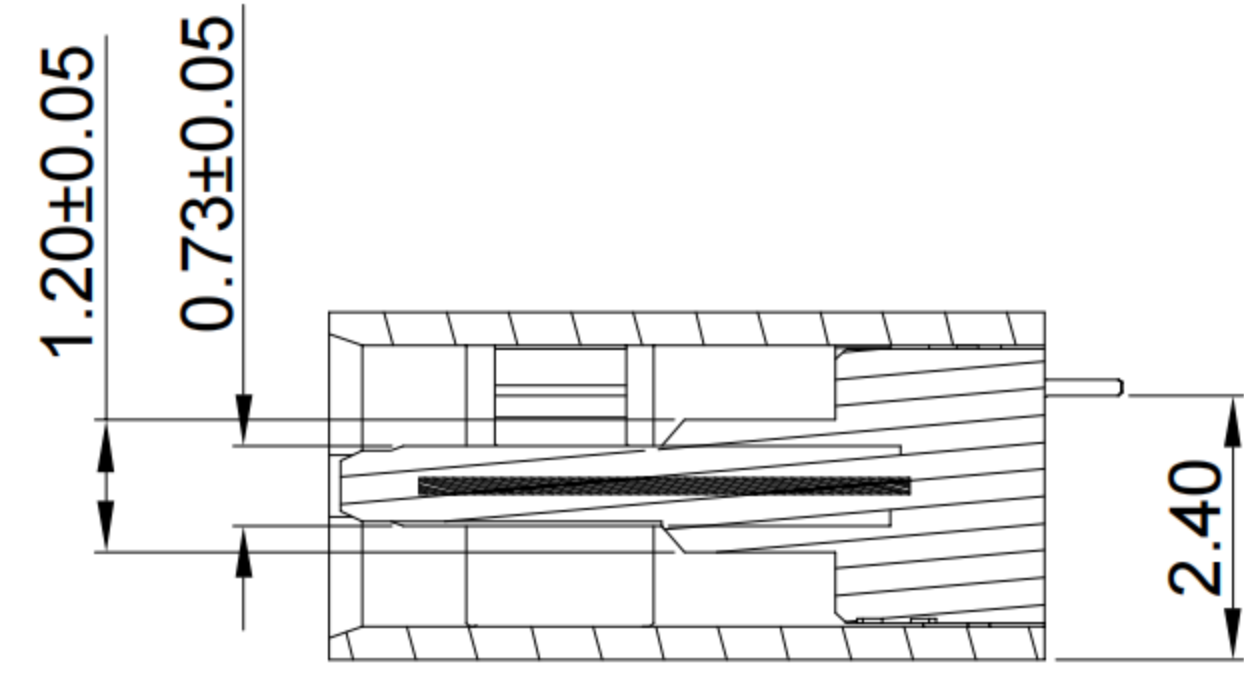
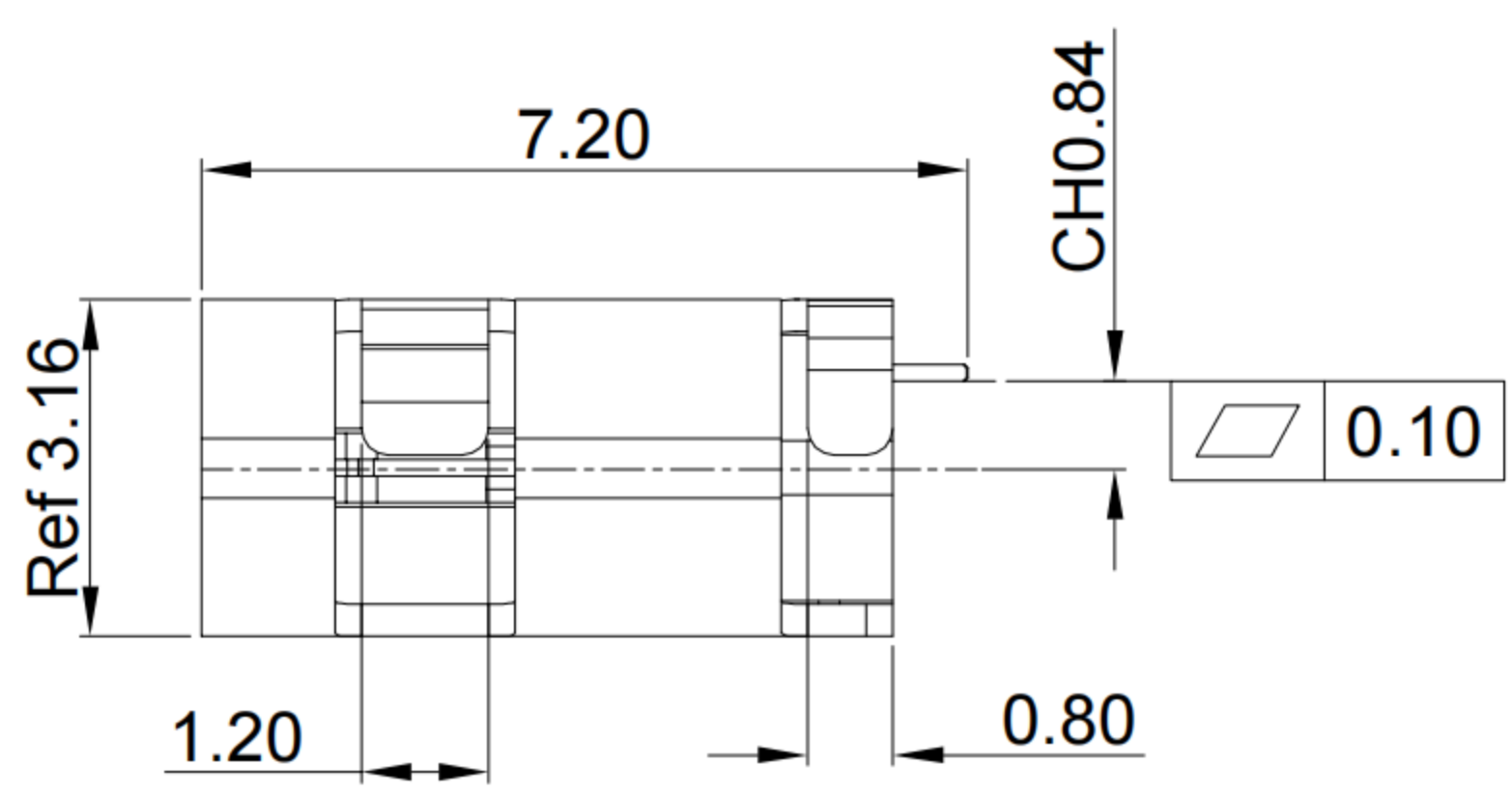
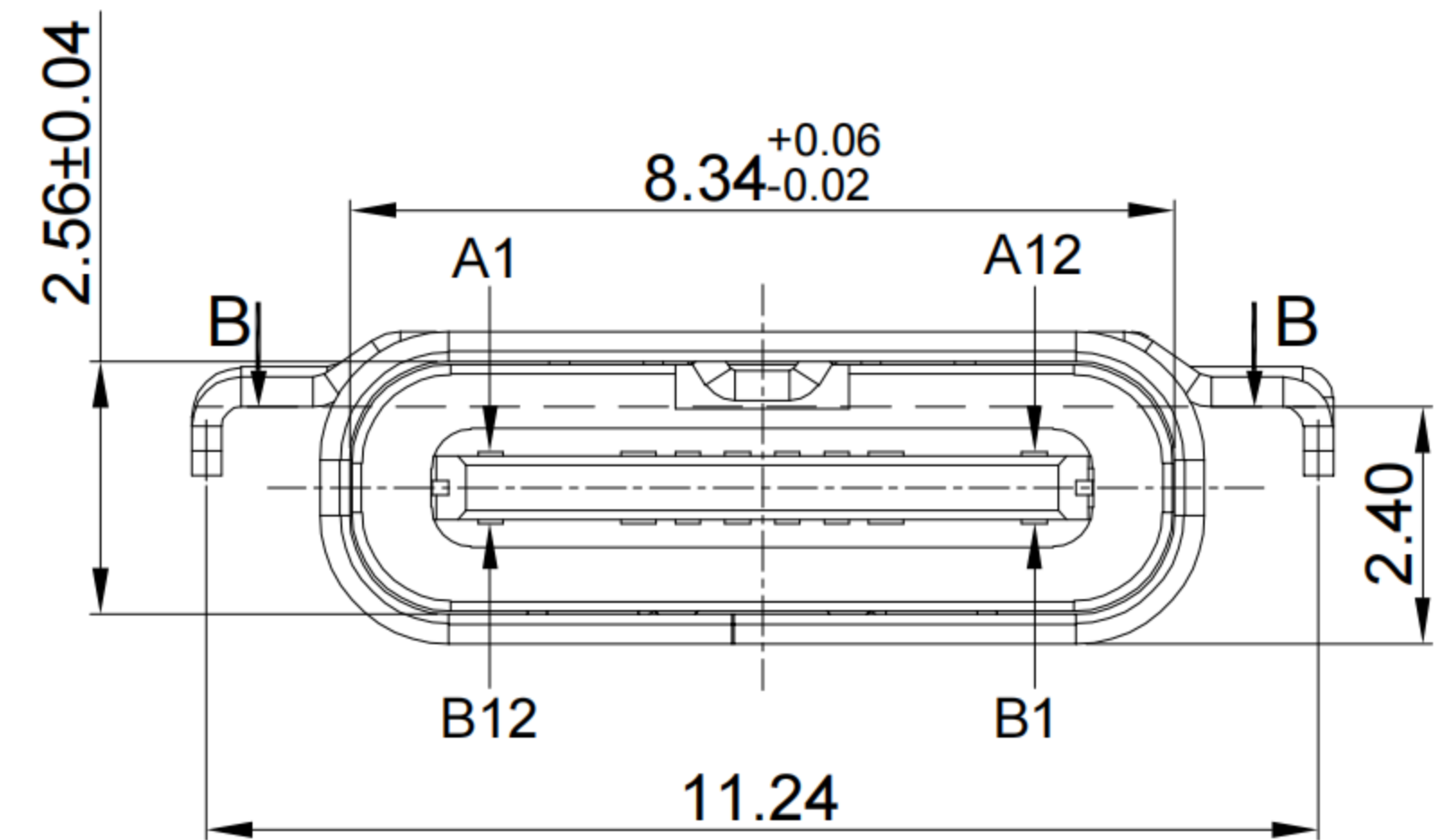

G-Switch USB-C Specification:

- 1.Current rated: 5A on vbus/1.25A on vconn/0.25A on other
Voltage rating: 24V AC
- 2.Withstanding voltage: 100V AC/minute
- 3.Contact resistance: 40mΩ Max
- 4.Insulation resistance: 100MΩ Min
- 5.Operating temperature: -40°C ~ +85°C
- 6.Mating force : 5N~20N
- 7.Unmating force: 8N~20N
- 8.Durability cycle:10,000 cycles

3

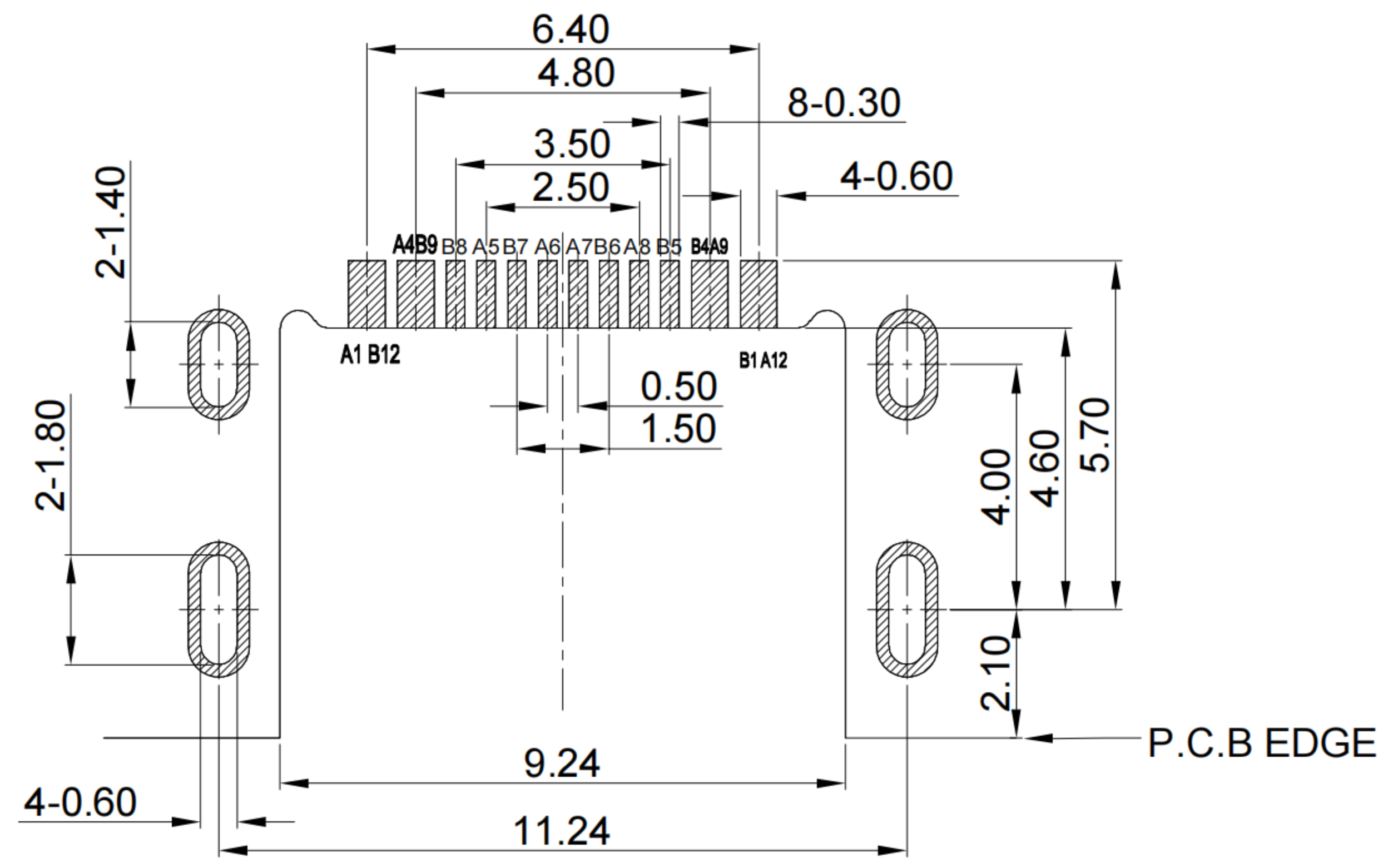
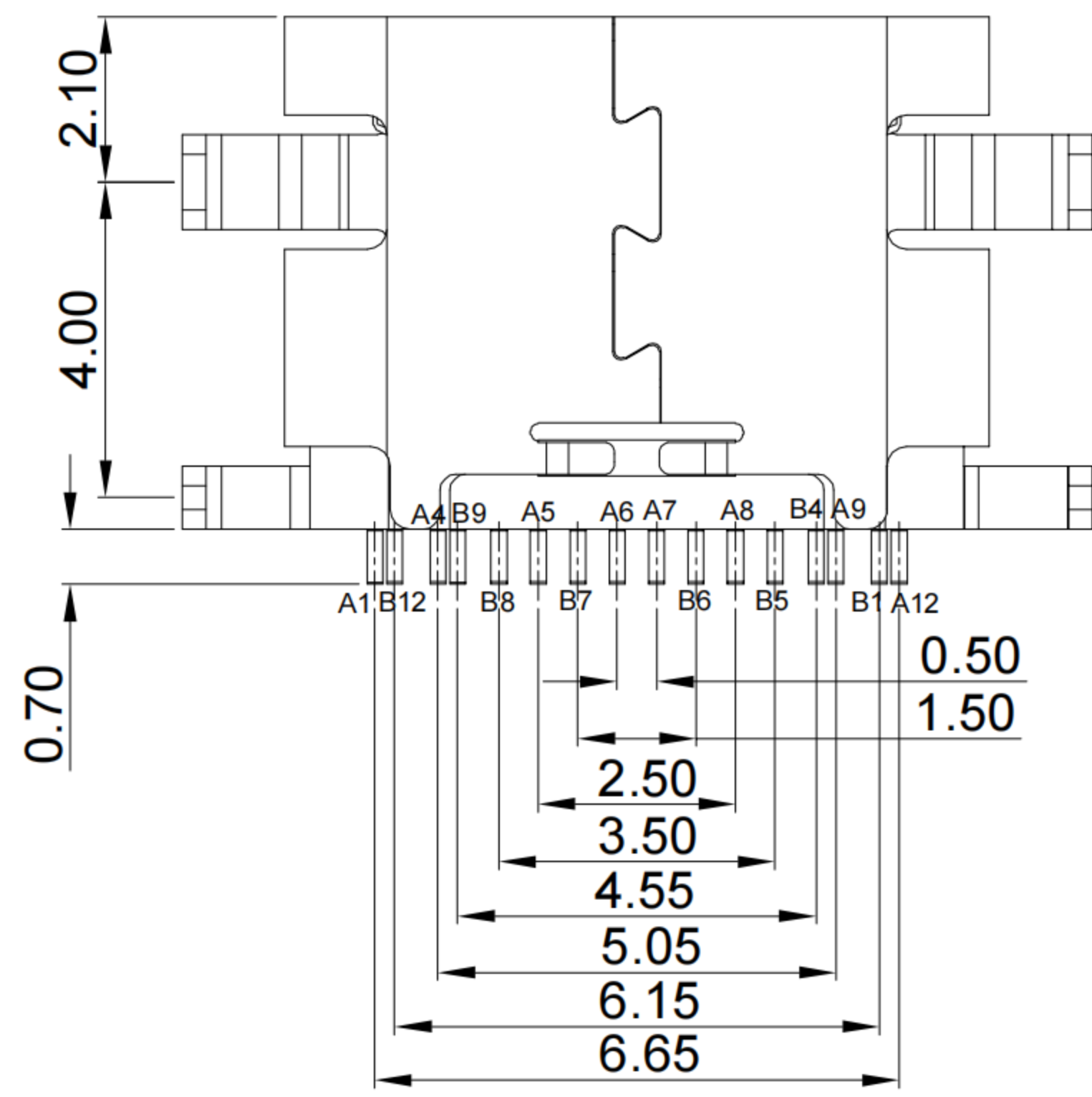

RECOMMENDED PCB LAYOUT
TOLERANCE:±0.05

| | | | | | | | | | | | |
|-------|-----|-----|-------|--------|--------|--------|--------|-------|-----|-----|-------|
| A1 | A2 | A3 | A4 | A5 | A6 | A7 | A8 | A9 | A10 | A11 | A12 |
| GND | | | VBUS | CC1 | D+ | D- | SBU1 | VBUS | | | GND |
| First | | | First | Second | Second | Second | Second | First | | | First |
| B12 | B11 | B10 | B9 | B8 | B7 | B6 | B5 | B4 | B3 | B2 | B1 |
| GND | | | VBUS | SBU2 | D- | D+ | CC2 | VBUS | | | GND |
| First | | | First | Second | Second | Second | Second | First | | | First |

4

| | | | |
|-----|-----------|--------------------------|----------------------------|
| 1 | SHELL | STAINLESS STEEL | NI PLATED |
| 2 | MID PLATE | STAINLESS STEEL | NI PLATED |
| 3 | HOUSING | HIGH TEMPERATURE PLASTIC | Black UL 94 V-0 |
| 4 | TERMINALS | COPPER ALLOY | Au PLATING ON CONTACT AREA |
| NO. | PARTS | MATERIAL | REMARKS |



SCALE: 1:1 UNIT: mm
 SIZE: A4

Unless otherwise
 General Tolerance:
 X. ±0.25
 X.x ±0.20
 X.xx ±0.15
 X.xxx ±0.10
 X° ±5°

Title: Horizontal Type-c 16P Female
 Sinker2.4 CH=0.84 L=6.5mm

Molde Code: GT-USB-7014H

| | | | |
|-------|---------|----------|------------|
| DRAWN | CHECKED | APPROVED | DATE |
| Xia | Chen | Chen | 2023.02.10 |



REV: A0 SHEET: 1/1

5