

1

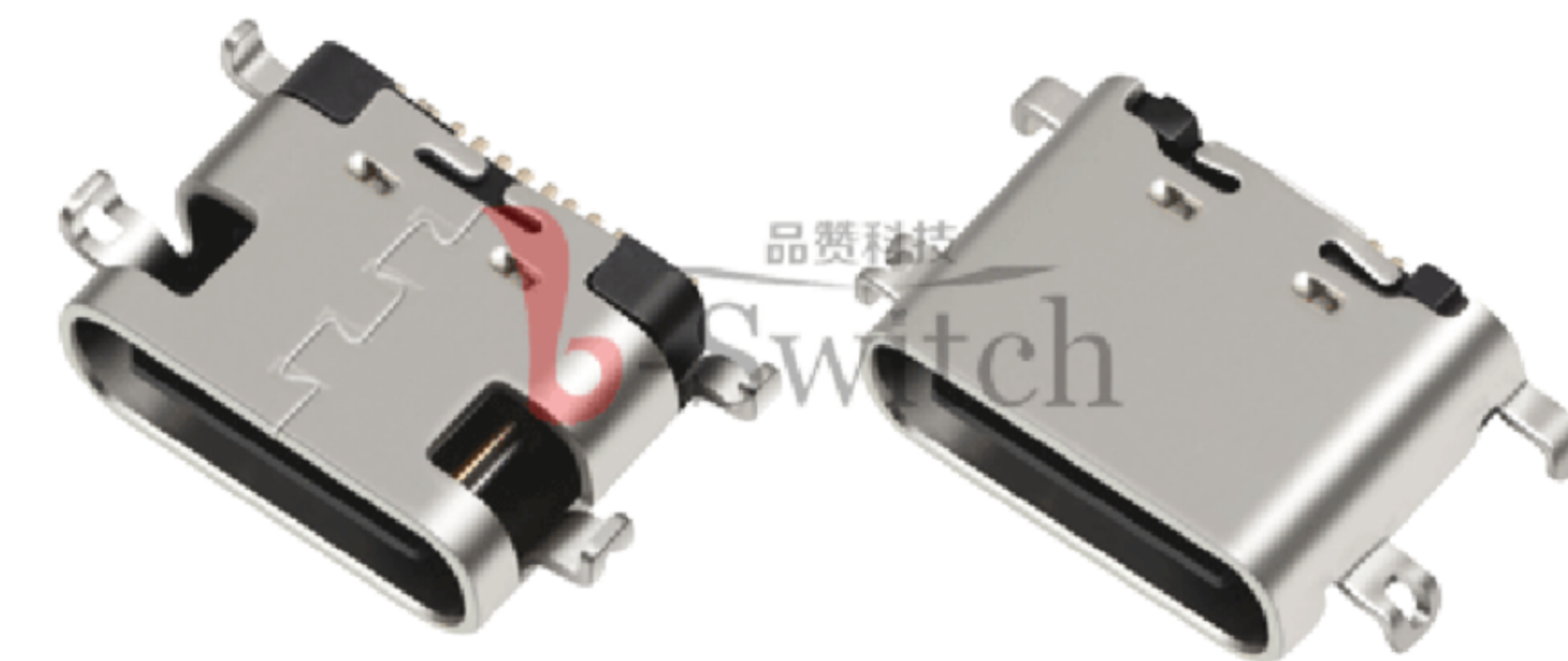

2

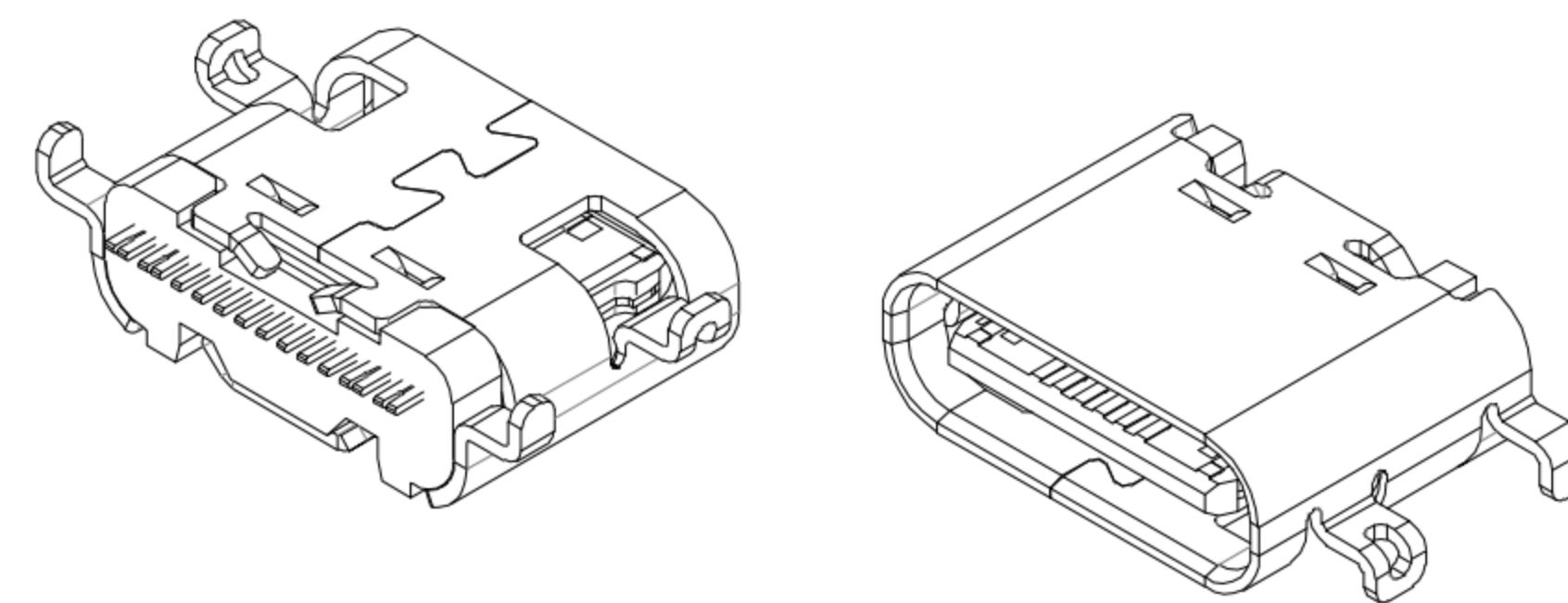
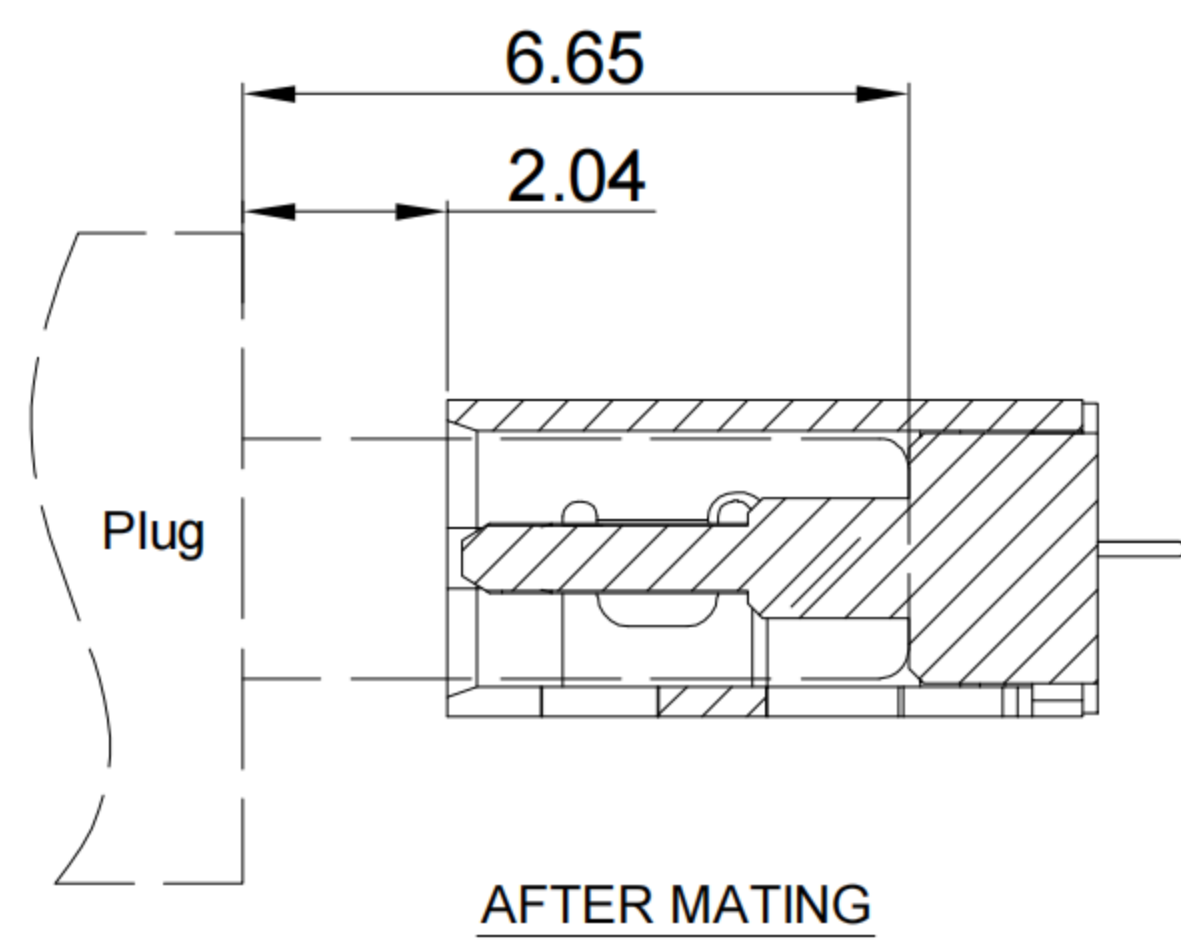
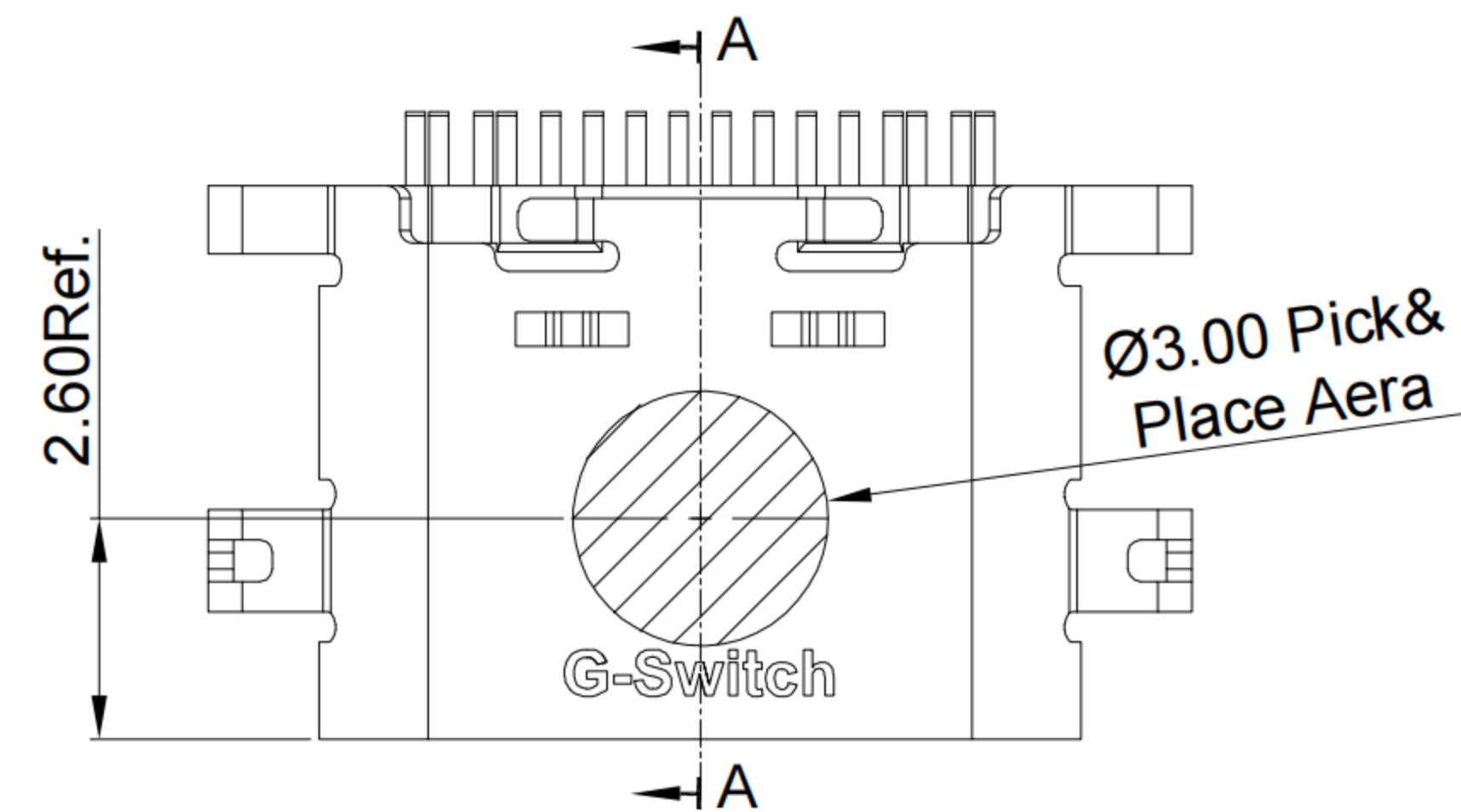
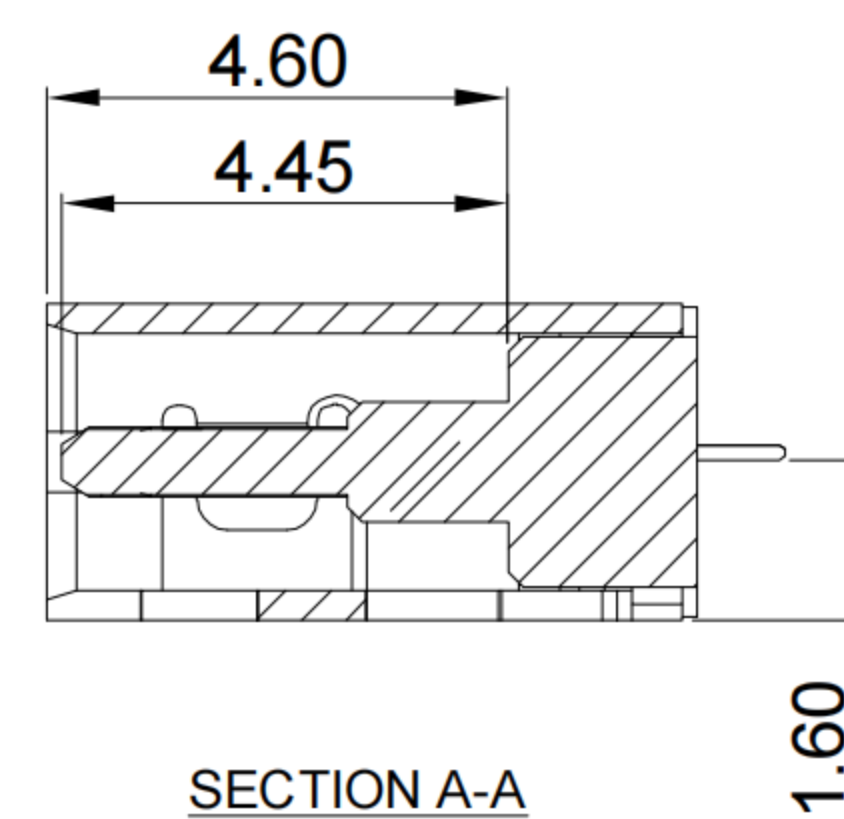
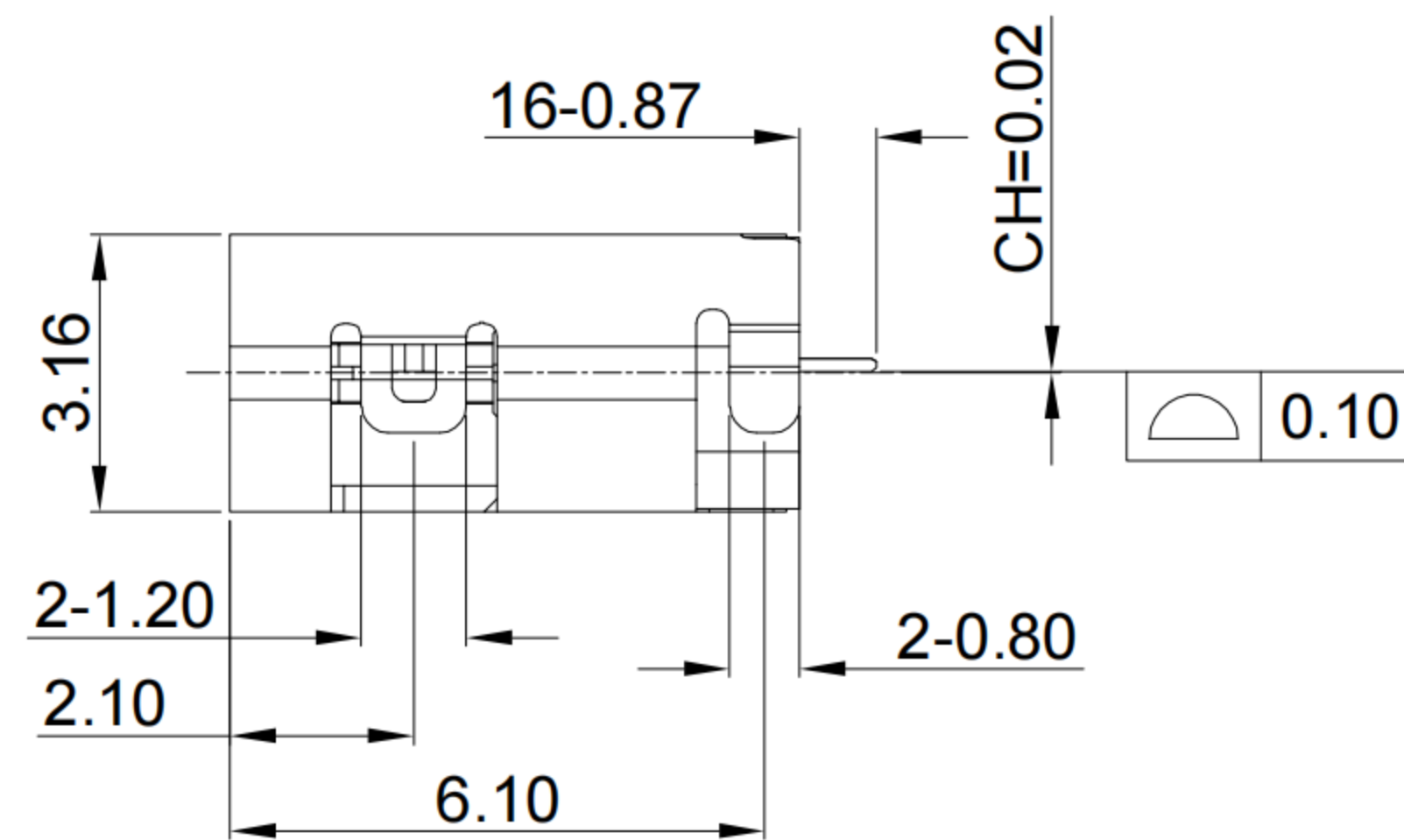
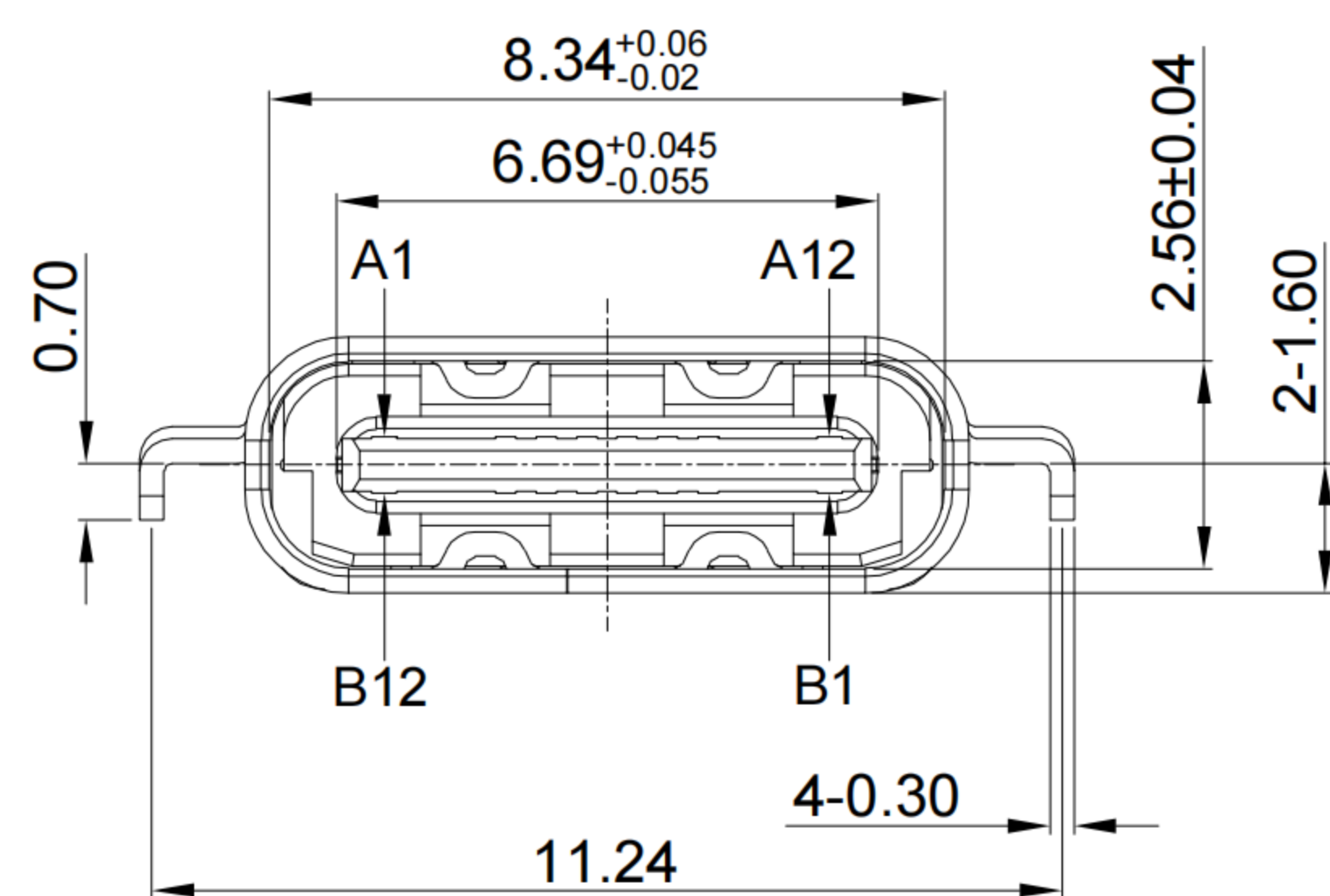

3

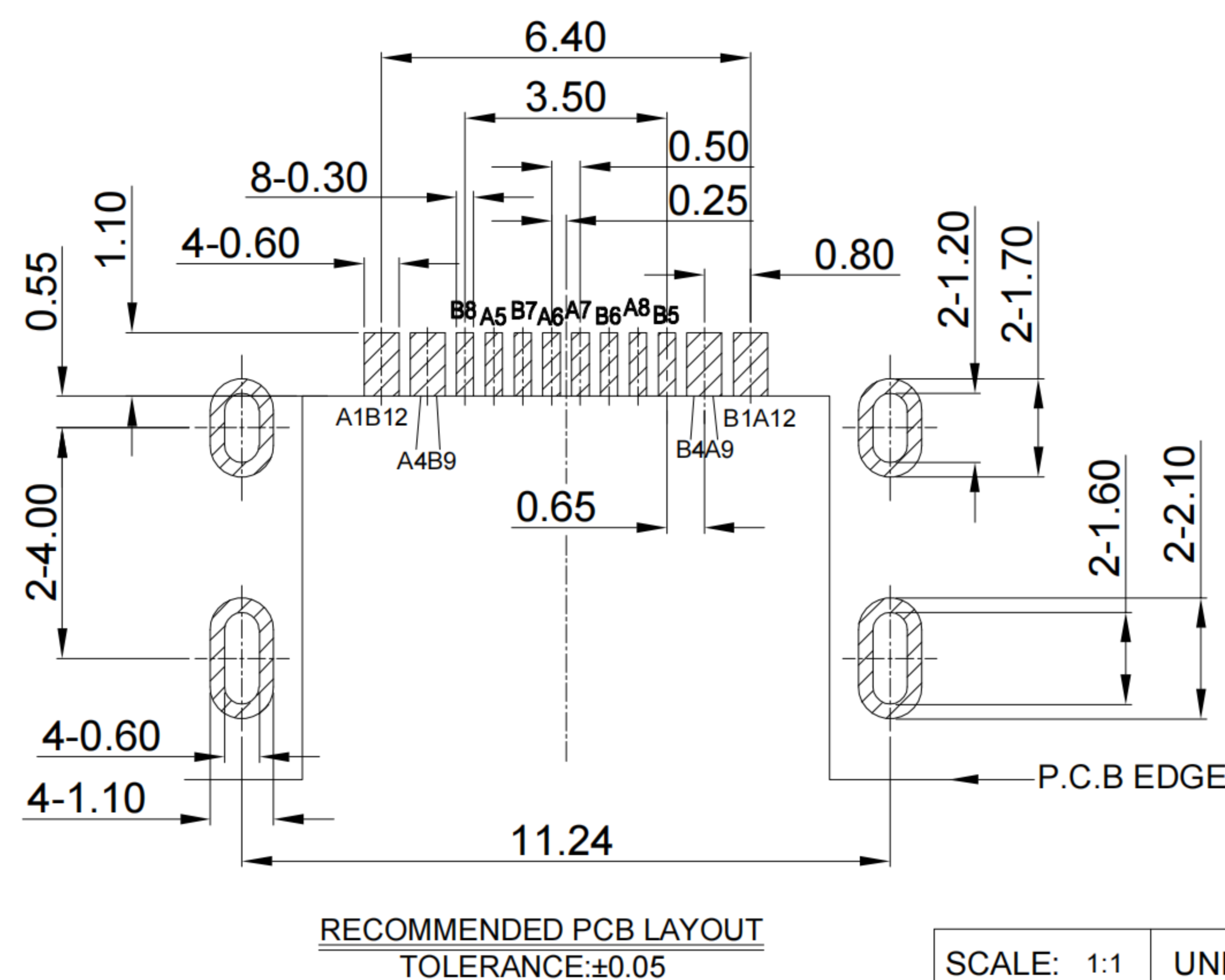
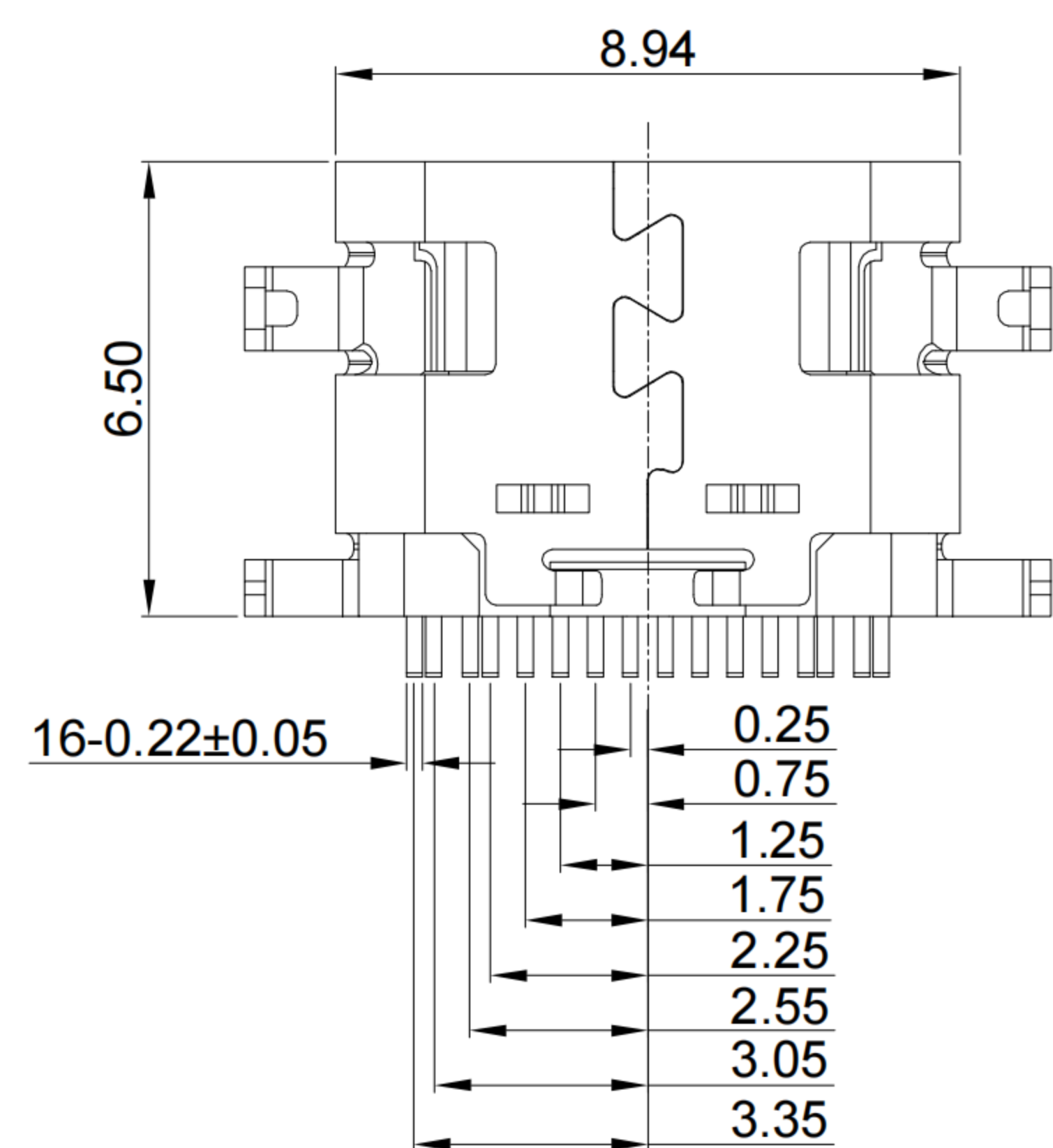

**G-Switch USB-C Specification:**

1. Current rated: 5A on vbus/1.25A on vconn/0.25A on other
2. Voltage rating: 24V AC
3. Withstanding voltage: 100V AC/minute
4. Contact resistance: 40mΩ Max
5. Insulation resistance: 100MΩ Min
6. Operating temperature: -40°C ~ +85°C
7. Mating force: 5N~20N
8. Unmating force: 8N~20N
9. Durability cycle: 10,000 cycles

A1	A2	A3	A4	A5	A6	A7	A8	A9	A10	A11	A12
GND			VBUS	CC1	D+	D-	SBU1	VBUS			GND
First			First	Second	Second	Second	Second	First			First
B12	B11	B10	B9	B8	B7	B6	B5	B4	B3	B2	B1
GND			VBUS	SBU2	D-	D+	CC2	VBUS			GND
First			First	Second	Second	Second	Second	First			First

5

1	SHELL	STAINLESS STEEL	Ni PLATED
2	MID PLATE	STAINLESS STEEL	Ni PLATED
3	HOUSING	HIGH TEMPERATURE PLASTIC	BLACK UL 94 V-0
4	TERMINALS	COPPER ALLOY	Au PLATING ON CONTACT AREA
NO.	PARTS	MATERIAL	REMARKS



SCALE: 1:1 UNIT: mm  
 SIZE: A4

Unless otherwise General Tolerance:  
 X. ±0.45  
 X.x ±0.35  
 X.xx ±0.25  
 X.xxx ±0.15  
 X° ±5°

Title: Horizontal Type-c 16P Female Sink1.6 SMT CH=0.02 L=6.5mm

Molde Code: GT-USB-7014C01

DRAWN	CHECKED	APPROVED	DATE
Xia	Chen	Chen	2023.02.01



REV: A0 SHEET: 1/1