

G-Switch USB-C Specification:

- 1.Current rated: 5A on vbus/1.25A on vconn/0.25A on other
Voltage rating: 24V AC
- 2.Withstanding voltage: 100V AC/minute
- 3.Contact resistance: 40mΩ Max
- 4.Insulation resistance: 100MΩ Min
- 5.Operating temperature: -40°C ~ +85°C
- 6.Mating force : 5N~20N
- 7.Unmating force: 8N~20N
- 8.Durability cycle:10,000 cycles
- 9.Data transmission rate up to 40Gbp/s

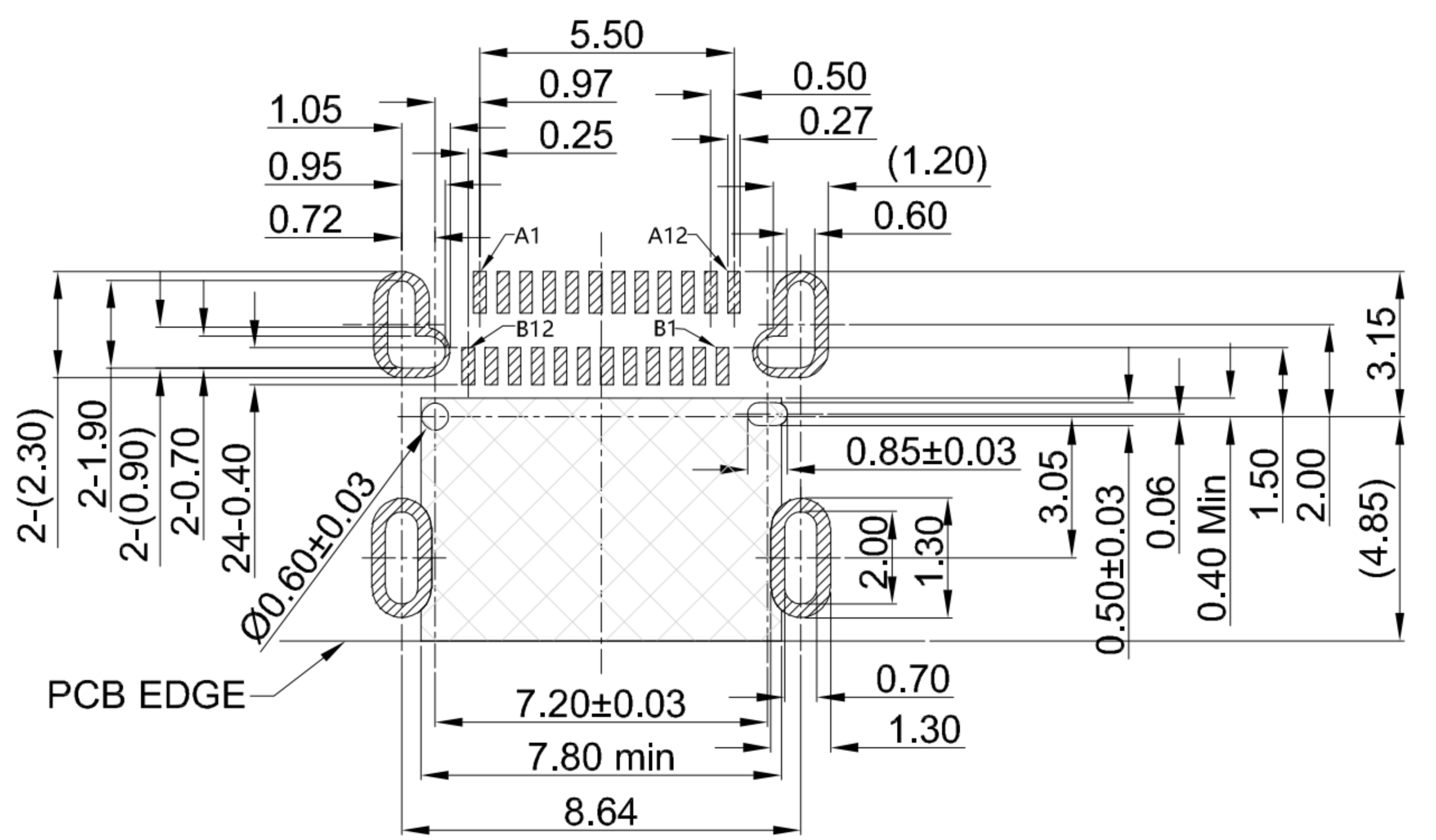
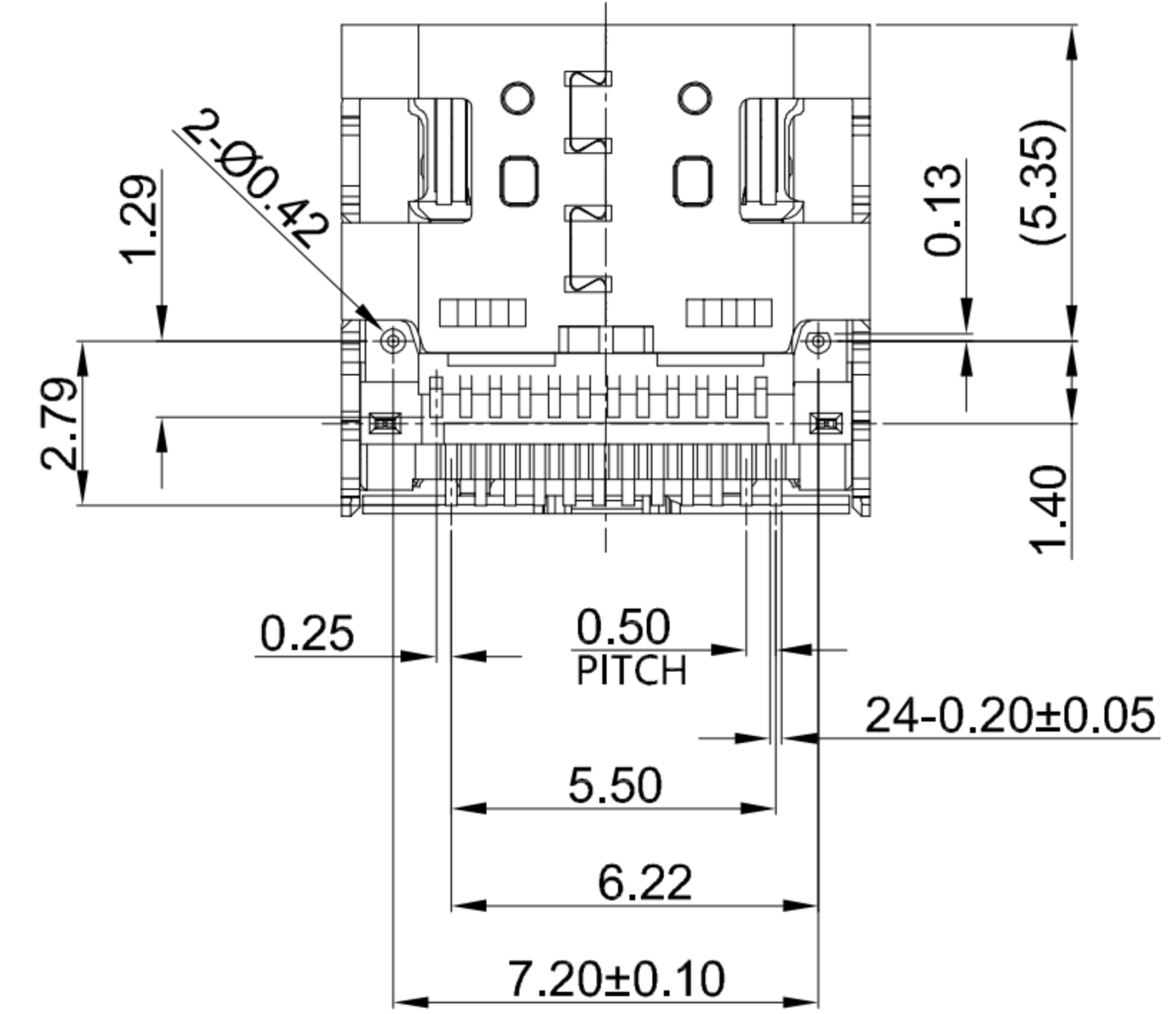

A1	A2	A3	A4	A5	A6	A7	A8	A9	A10	A11	A12
GND	TX1+	TX1-	VBUS	CC1	D+	D-	SBU1	VBUS	RX2-	RX2+	GND
First	Second	Second	First	Second	Second	Second	Second	First	Second	Second	First
B12	B11	B10	B9	B8	B7	B6	B5	B4	B3	B2	B1
GND	RX1+	RX1-	VBUS	SBU2	D-	D+	CC2	VBUS	TX2-	TX2+	GND
First	Second	Second	First	Second	Second	Second	Second	First	Second	Second	First

RECOMMENDED PCB LAYOUT
TOLERANCE:±0.05

1	SHELL	STAINLESS STEEL	NI PLATED
2	MID PLATE	STAINLESS STEEL	NI PLATED
3	HOUSING	HIGH TEMPERATURE PLASTIC	Black UL 94 V-0
4	TERMINALS	COPPER ALLOY	Au PLATING ON CONTACT AREA
NO.	PARTS	MATERIAL	REMARKS



SCALE: 1:1 UNIT: mm
 SIZE: A4
 Unless otherwise General Tolerance:
 X. ±0.25
 X.x ±0.20
 X.xx ±0.15
 X.xxx ±0.10
 X° ±5°

Title: Horizontal Type-c 24P Female
SMT CH=1.6 L=8.17mm Pin0.6mm
 Molde Code: GT-USB-7013B01
 DRAWN: Xia CHECKED: Chen APPROVED: Chen DATE: 2023.02.01



REV: A0 SHEET: 1/1