

1

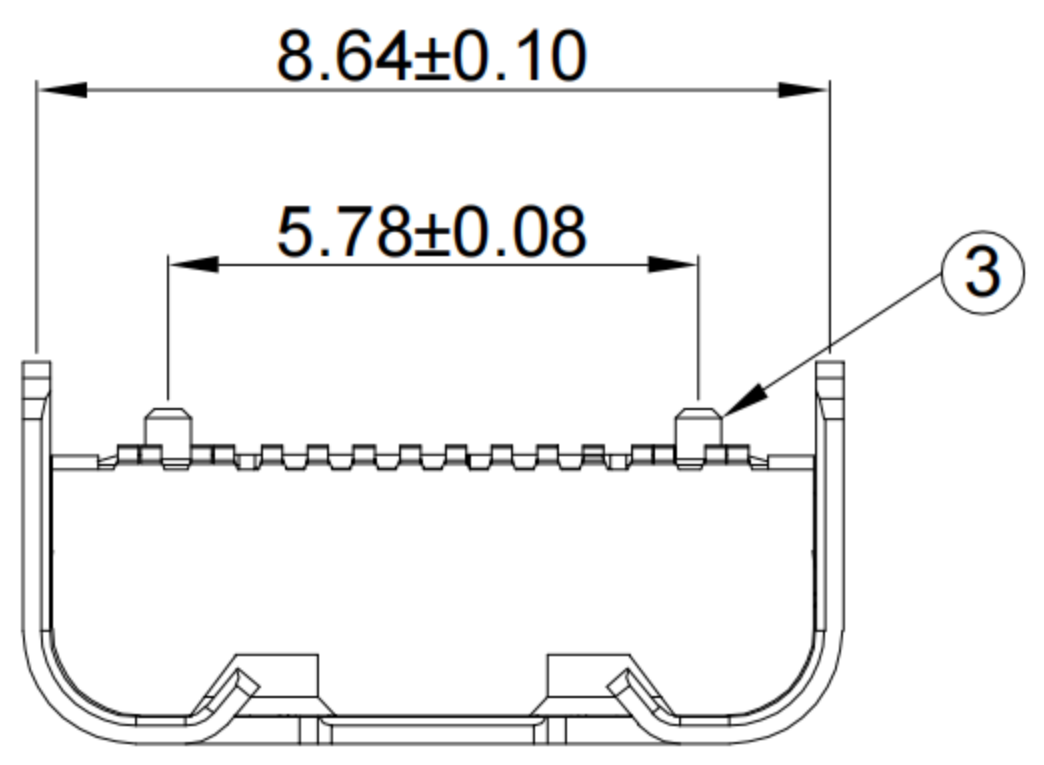

2

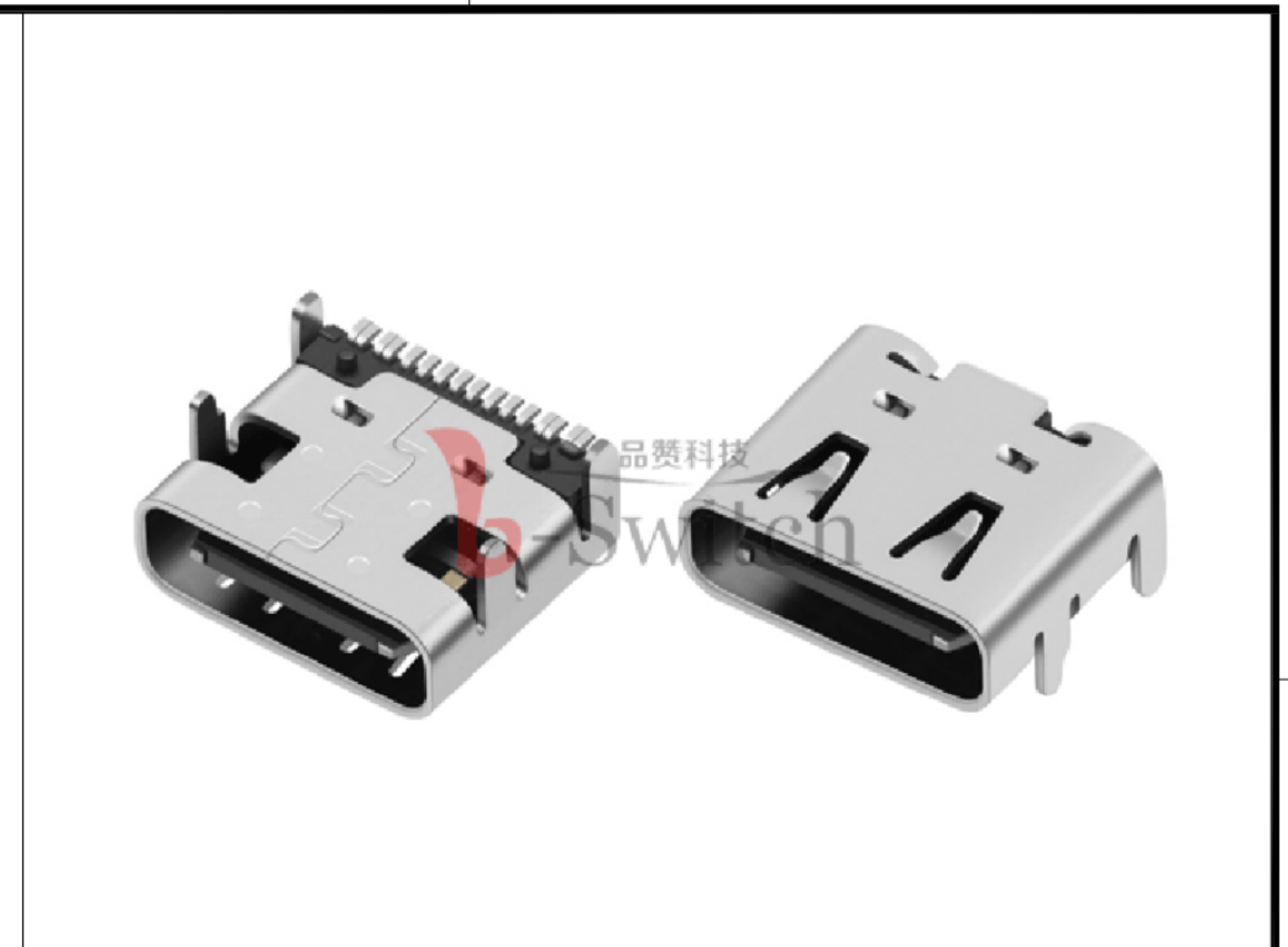
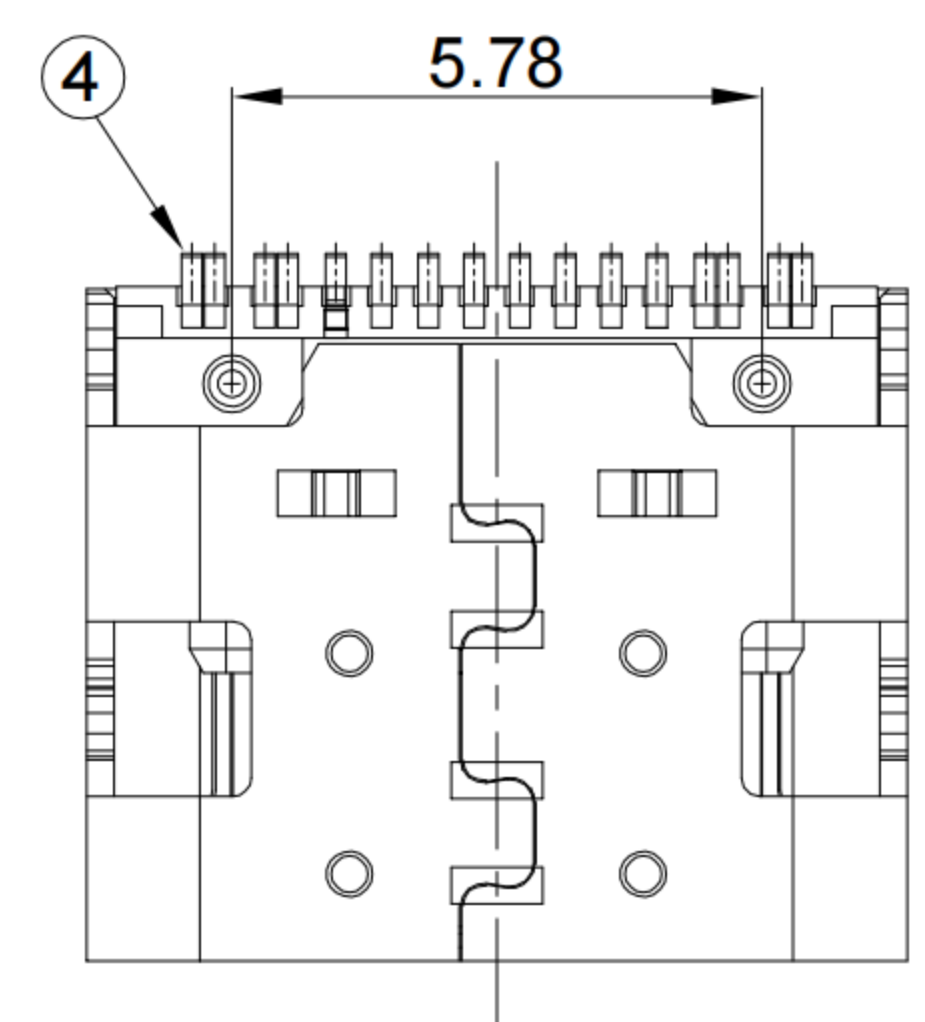
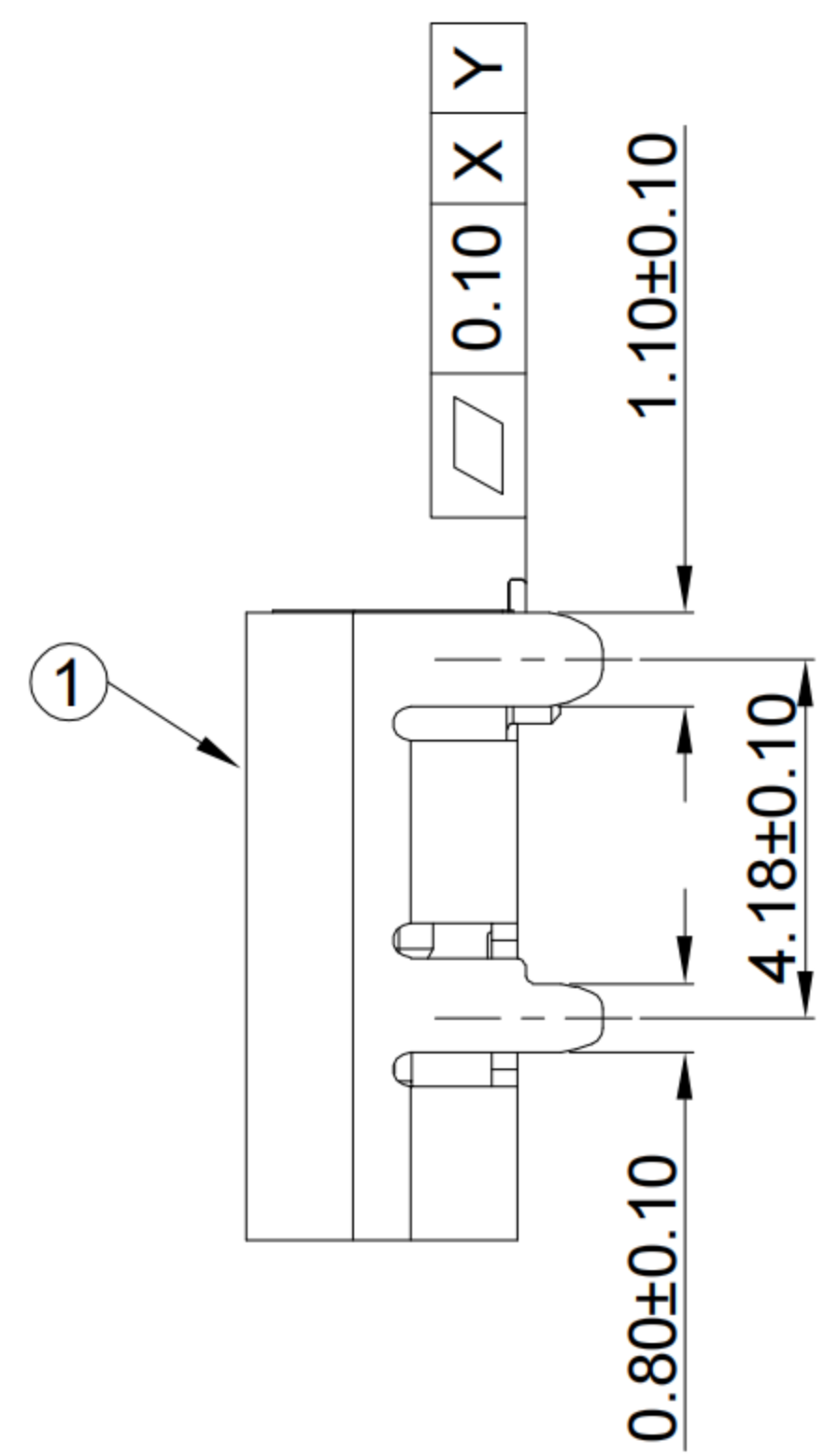
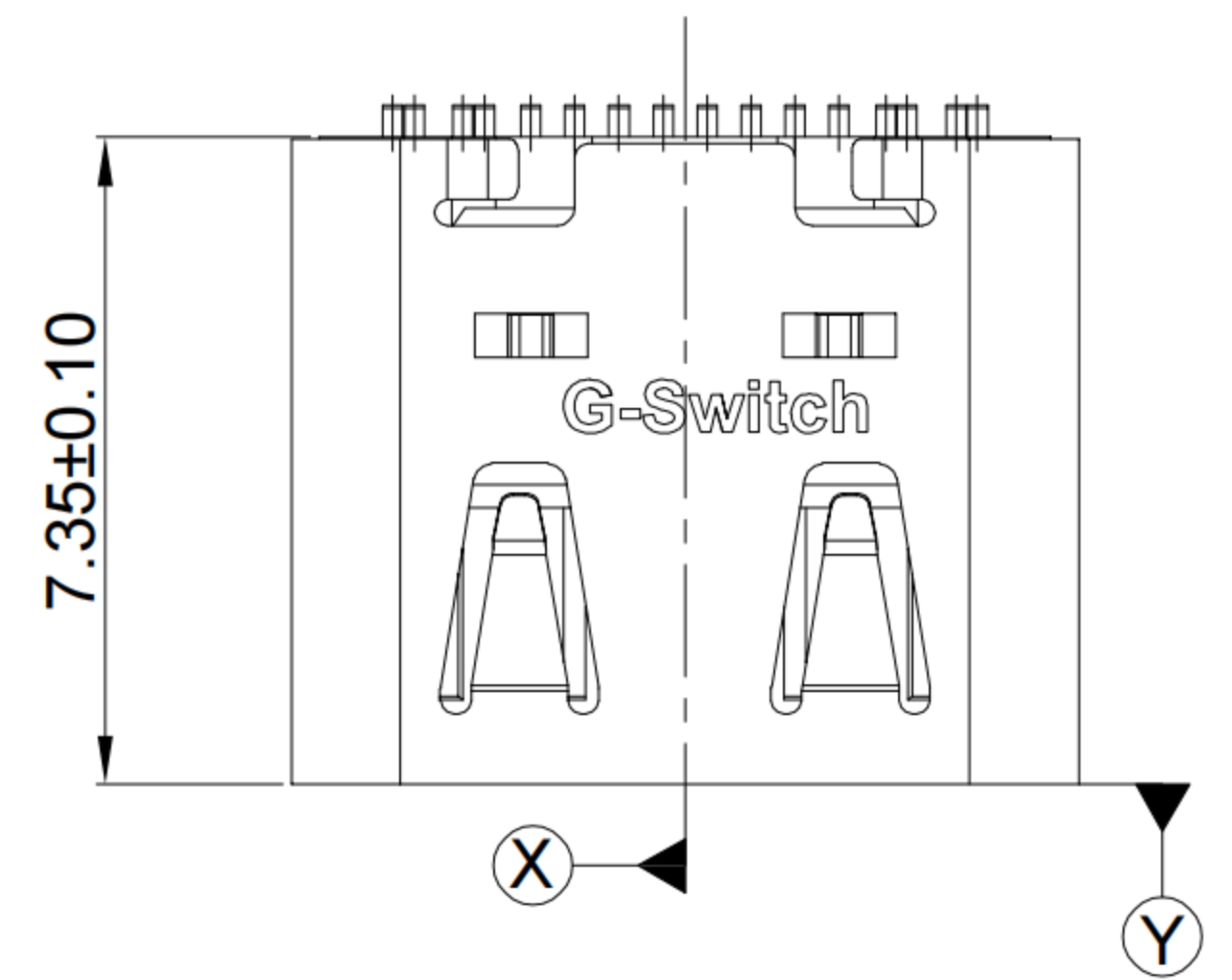

3

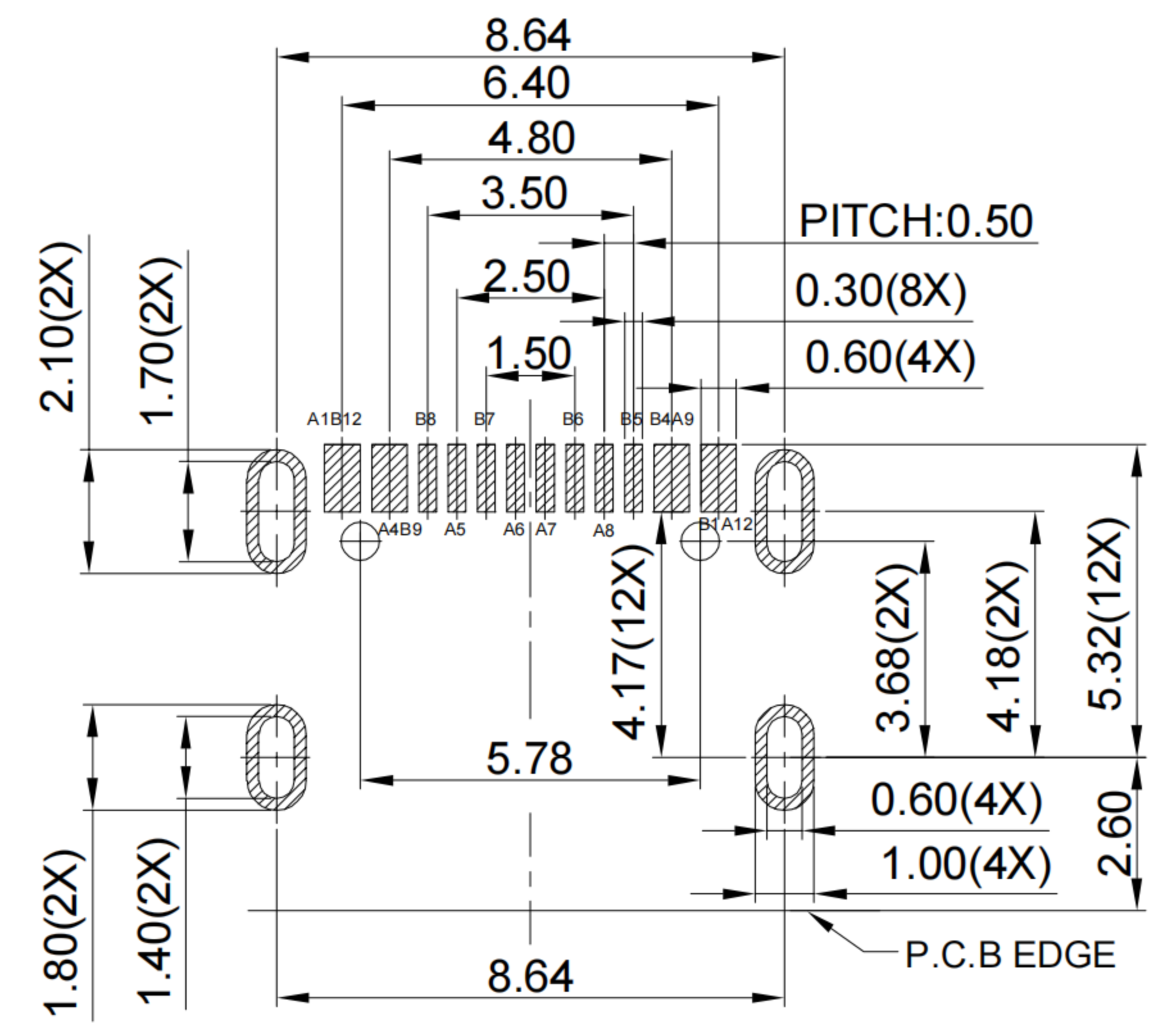
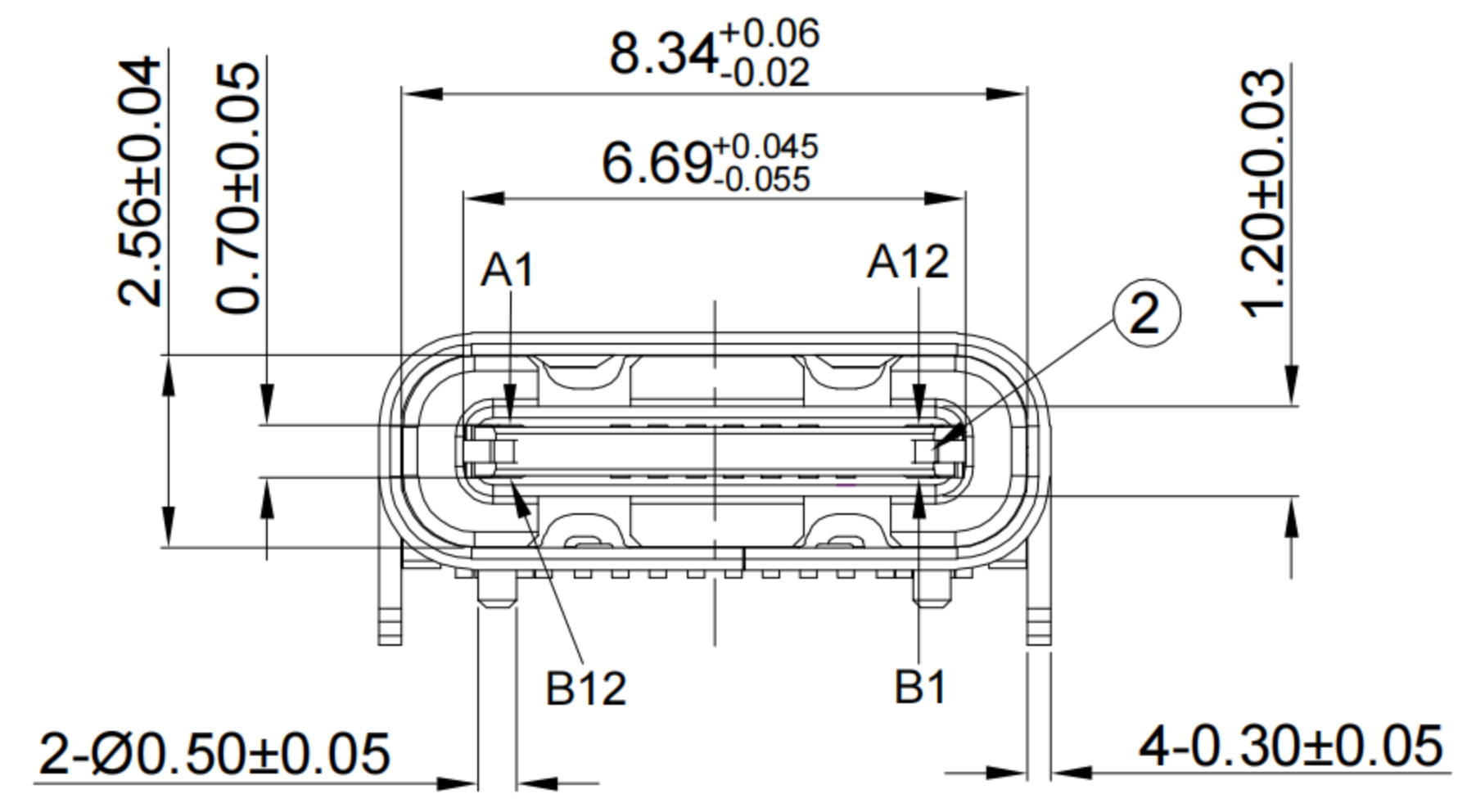

G-Switch USB-C Specification:

1. Current rated: 10A on vbus/1.25A on vconn/0.25A on other
- Voltage rating: 24V AC
- Temperature variation not exceeding 30 °C
2. Withstanding voltage: 100V AC/minute
3. Contact resistance: 40mΩ Max
4. Insulation resistance: 100MΩ Min
5. Operating temperature: -40°C ~ +85°C
6. Mating force: 5N~20N
7. Unmating force: 5N~20N
8. Durability cycle: 30,000 cycles
9. Salt spray test: 48H

A1	A2	A3	A4	A5	A6	A7	A8	A9	A10	A11	A12
GND			VBUS	CC1	D+	D-	SBU1	VBUS			GND
First			First	Second	Second	Second	Second	First			First
B12	B11	B10	B9	B8	B7	B6	B5	B4	B3	B2	B1
GND			VBUS	SBU2	D-	D+	CC2	VBUS			GND
First			First	Second	Second	Second	Second	First			First

4

RECOMMENDED PCB LAYOUT
TOLERANCE: ±0.05

5

1	SHELL	STAINLESS STEEL	Ni PLATED
2	MID PLATE	STAINLESS STEEL	Ni PLATED
3	HOUSING	HIGH TEMPERATURE PLASTIC	BLACK UL 94 V-0
4	TERMINALS	COPPER ALLOY	Au PLATING ON CONTACT AREA
NO.	PARTS	MATERIAL	REMARKS



SCALE: 1:1	UNIT: mm
SIZE: A4	
Unless otherwise General Tolerance:	
X.	±0.25
X.x	±0.20
X.xx	±0.15
X.xxx	±0.10
X°	±5°

Title: Horizontal Type-c 16P Female SMT CH1.68mm Current 10A			
Molde Code: GT-USB-7010ES01			
DRAWN	CHECKED	APPROVED	DATE
Xia	Chen	Chen	2023.02.01

