

G-Switch USB-C Specification:

- 1.Current rated: 5A on vbus/1.25A on vconn/0.25A on other
Voltage rating: 24V AC
- 2.Withstanding voltage: 100V AC/minute
- 3.Contact resistance: 40mΩ Max
- 4.Insulation resistance: 100MΩ Min
- 5.Operating temperature: -40°C ~ +85°C
- 6.Mating force : 5N~20N
- 7.Unmating force: 8N~20N
- 8.Durability cycle:10,000 cycles
- 9.Waterproof grade: IP-X7

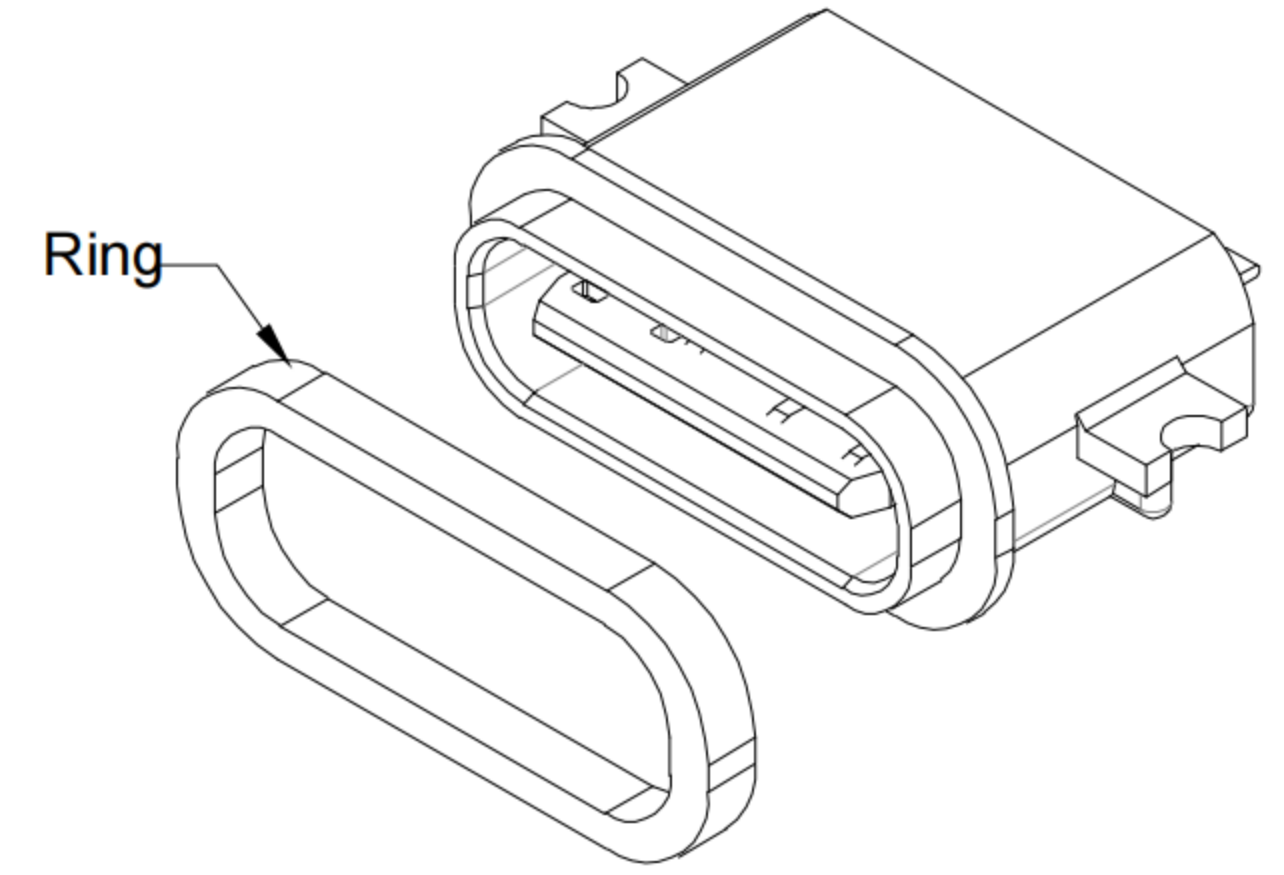
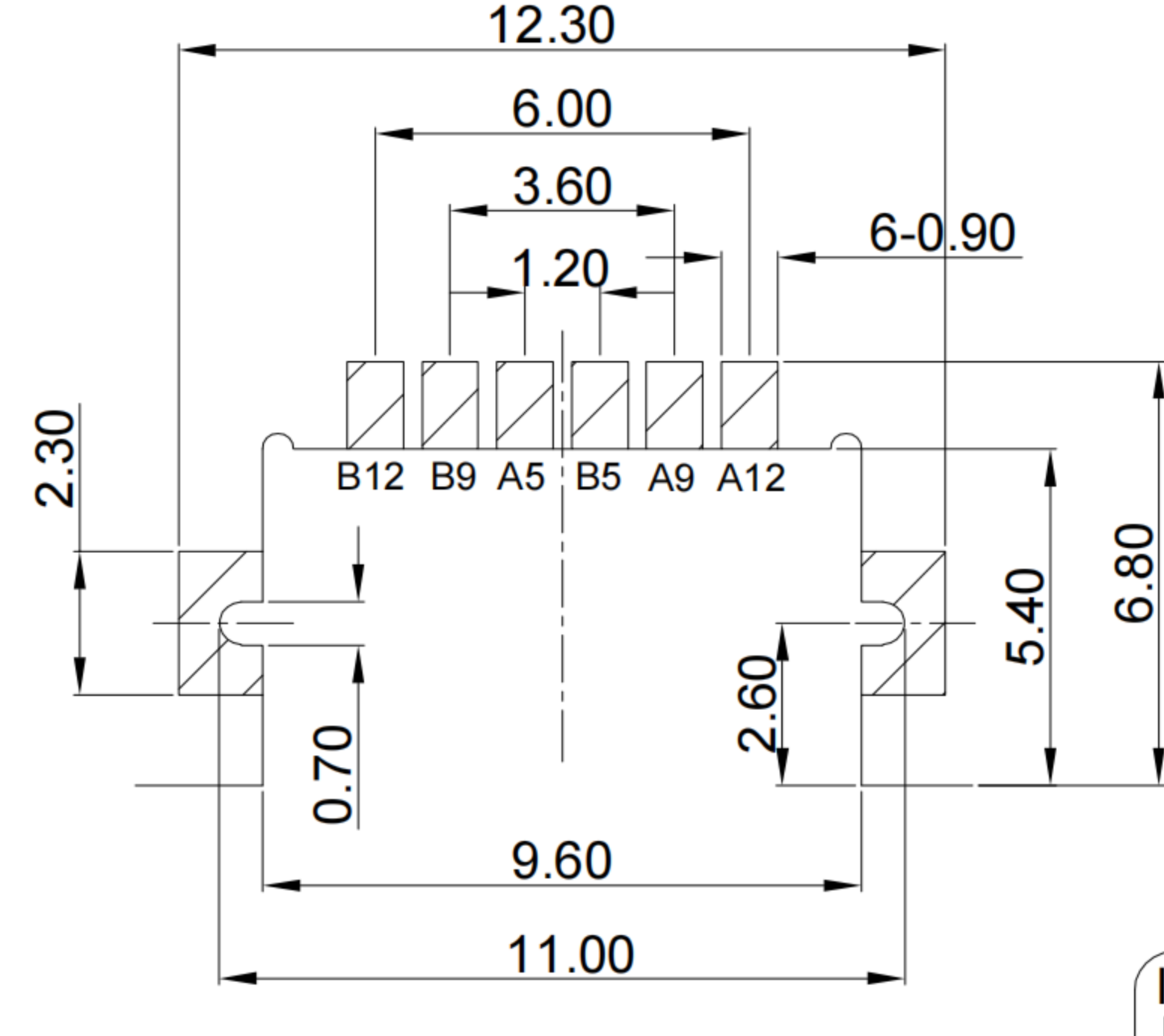
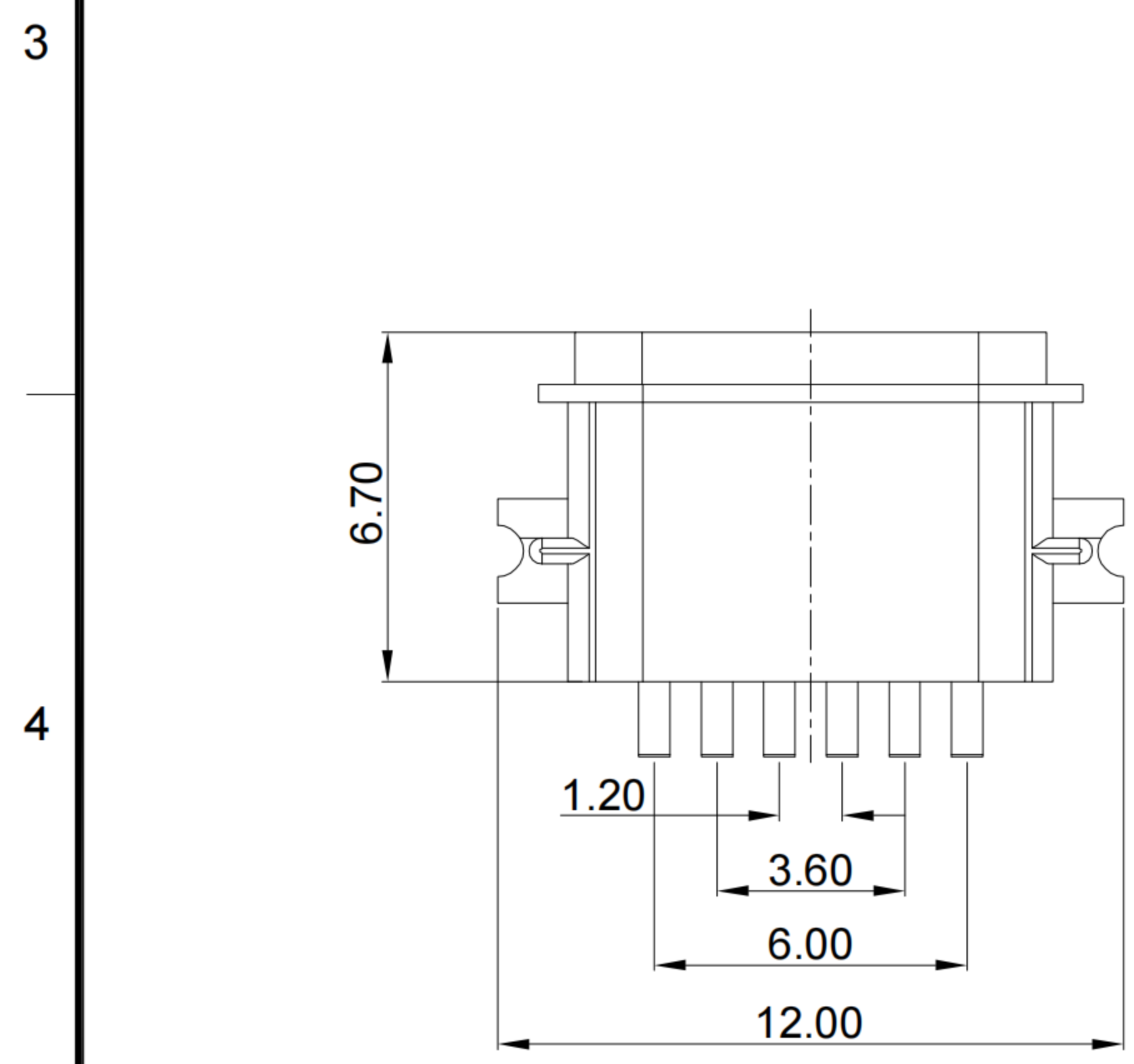

A1	A2	A3	A4	A5	A6	A7	A8	A9	A10	A11	A12
				CC1				VBUS			GND
				Second				First			First
B12	B11	B10	B9	B8	B7	B6	B5	B4	B3	B2	B1
GND			VBUS				CC2				
First			First				Second				

PCB Layout For Reference Only
Tolerance:±0.05

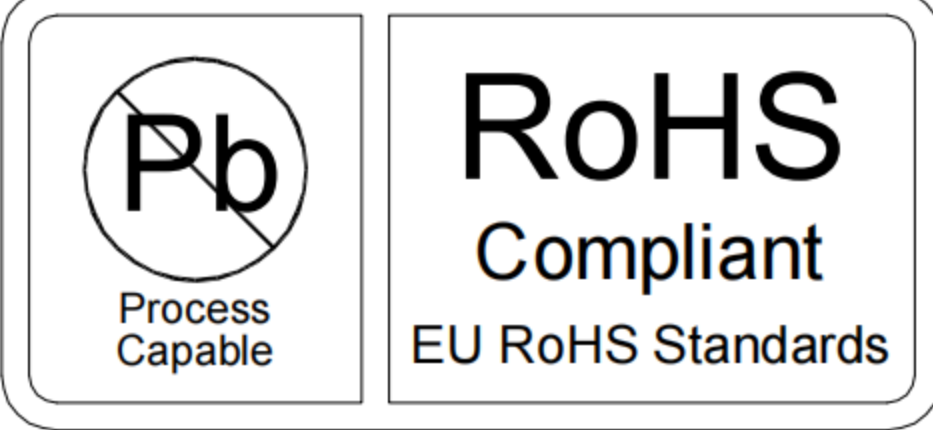
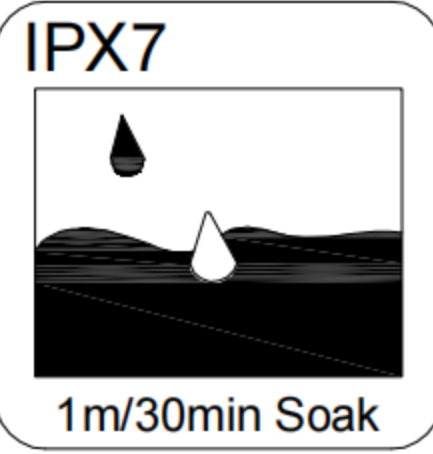

SCALE: 1:1 UNIT: mm
SIZE: A4

Title: Horizontal Type-c 6P Female Sinker1.6 L=6.7mm

Unless otherwise
General Tolerance:
X. ±0.25
X.x ±0.20
X.xx ±0.15
X.xxx ±0.10
X° ±5°

Molde Code: GT-USB-7008C

DRAWN	CHECKED	APPROVED	DATE
Xia	Chen	Chen	2023.02.31



REV: A0 SHEET: 1/1

1	SHELL	STAINLESS STEEL	NI PLATED
2	MID PLATE	STAINLESS STEEL	
3	HOUSING	HIGH TEMPERATURE PLASTIC	LCP BLACK UL 94 V-0
4	TERMINALS	COPPER ALLOY	Au PLATING ON CONTACT AREA
NO.	PARTS	MATERIAL	REMARKS