

GT-TC194X-HXXXX-LX

G-SWITCH



Operating Force
 A=160gf
 B=250gf
 C=100gf

Switch Height (mm)
 H0053=0.53mm
 (OF:A, C)
 H0055=0.55mm
 (OF:B)

Switch lifetime (Force)
 L1=100,000 Cycles
 L3=300,000 Cycles

G-Switch Specification:

Operating temperature range : -30°Cto+85°C
 Rating : 50mA.12V DC
 Insulation resistance : 100MΩ min.100V DC
 Dielectric strength : 250V AC for 1 min
 Contact resistance : 100m Ω max.
 Travel:0.15±0.05mm

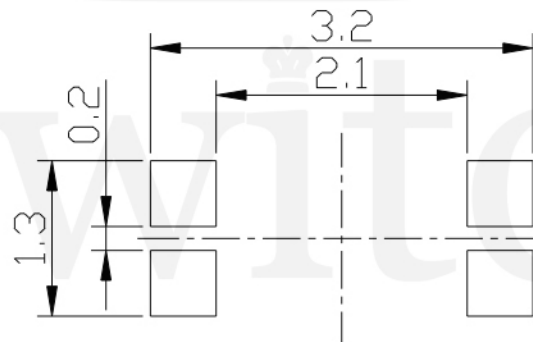
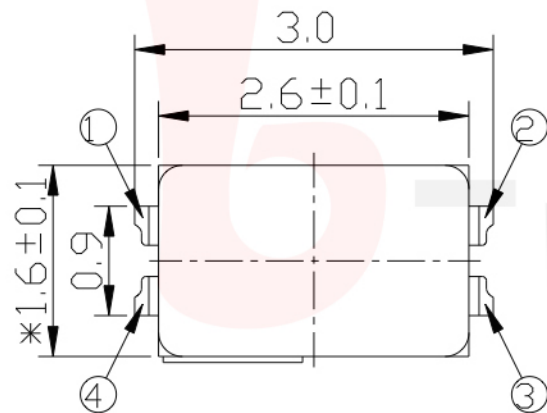

P.C.B LAND DIMENSION

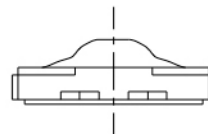

CIRCUIT DIAGRAM

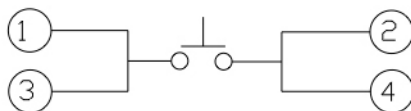

<p>品贊科技®</p> <p>Unless otherwise specified, Tolerance: X. ±0.30 X.x ±0.20 X.xx ±0.15 X.xxx ±0.10 Angles ±3°</p>	G-Switch Electronic (HongKong) CO.,Ltd.		
	DESIGN FengFengChen	DATE 2019.05.29	Molde code: GT-TC194X-HXXXX-LX
	CHECKED	DATE	
	APPROVED	DATE	REV.: X1 SCALE: 4:1 UNIT: mm SIZE: A4 SHEET: 1/1
http://www.dg-switch.com		TEL:0769-82388879	

品贊科技

Switch