

A

B

C

D

E

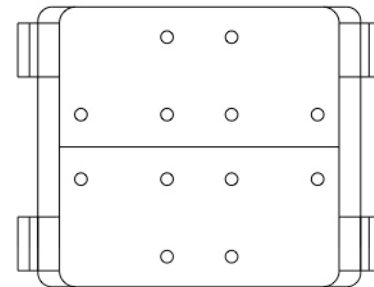
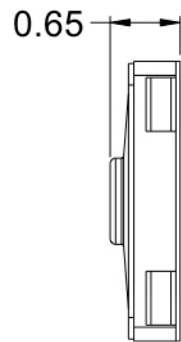
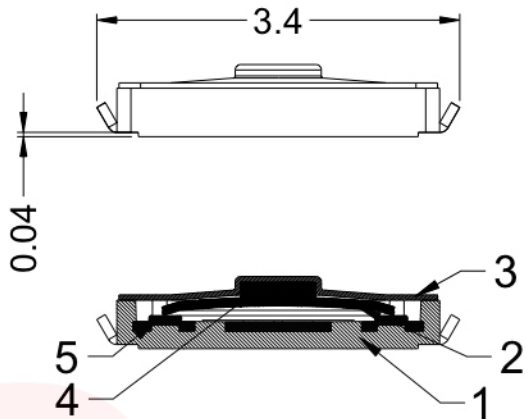

GT-TC025X-HXXXX-LX

G-SWITCH

Operating Force

A=160gf

B=200gf

C=300gf

D=250gf

E=120gf

Switch Height (mm)

H0065=0.065mm

Switch lifetime (Force)

L1=100,000 Cycles

L3=300,000 Cycles

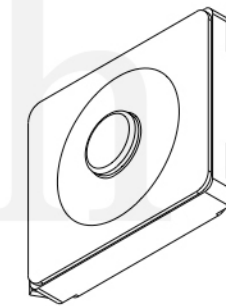

G-Switch Specification:

Operating temperature range : -30°Cto+85°C

Rating : 50mA.12V DC

Insulation resistance: : 100MΩ min.100V DC

Dielectric strength : 250V AC for 1 min

Contact resistance: : 100m Ω max.

Travel:0.15±0.05mm

品赞科技

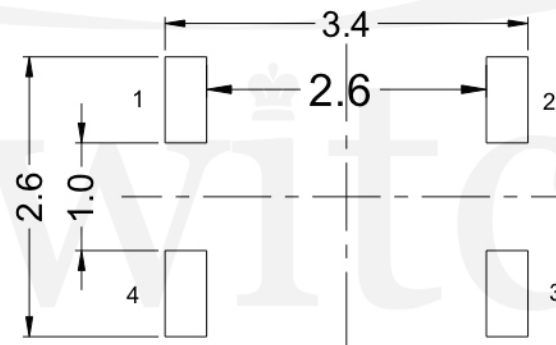
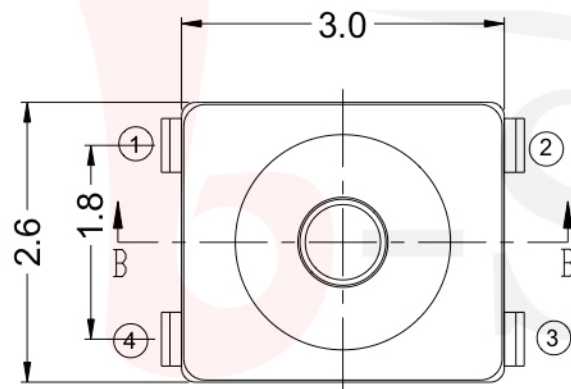

P.C.B LAND DIMENSION

Circuit Diagram

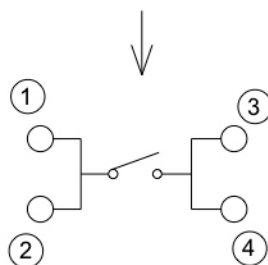

Unless otherwise specified, Tolerance:
 X. ±0.30
 X.x ±0.20
 X.xx ±0.15
 X.xxx ±0.10
 Angles ±3°

G-Switch Electronic (HongKong) CO.,Ltd.

DESIGN FengFengChen

DATE 2019.05.29

Molde code:

CHECKED

DATE

GT-TC025X-HXXXX-LX

APPROVED

DATE

<http://www.dg-switch.com>

REV.: X1

SCALE: 4:1

UNIT: mm

TEL:0769-82388879

SIZE: A4

SHEET: 1/1

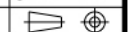

A

B

C

D

E